

## DE Aufbauanleitung Gerätehaus „AvantGarde“ Gr. XXL

- Ⓞ GB Assembly manual for garden shed „AvantGarde“ XXL
- Ⓞ FR Notice de montage pour l’abri de jardin „AvantGarde“ taille XXL
- Ⓞ NL Opbouwbeschrijving berging „AvantGarde“ grotte XXL
- Ⓞ IT Istruzioni di montaggio Casetta portattrezzi “AvantGarde” misura XXL
- Ⓞ ES Instrucciones de montaje de la caseta modelo “AvantGarde” tamaño XXL





## Wichtige Punkte für den Aufbau!

Vorliegende Aufbauanleitung zeigt den Zusammenbau von „AvantGarde“ Größe „XXL“. Für einige Montageschritte benötigen Sie 1 bis 2 Helfer.

- (GB) *Important details regarding assembly! This assembly manual shows the erection of the garden shed model "AvantGarde" size "XXL". For several assembly steps additional assistance of 1 or 2 people will be required.*
- (FR) *Points importants lors du montage! " Cette notice de montage décrit l'assemblage de l'abri „AvantGarde“ taille « XXL ». Pour certaines étapes, demandez l'aide d'une ou deux personnes.*
- (NL) *Deze montage instructies hebben betrekking op de opbouw van de AvantGarde , grootte XXL. Voor enkele montage stappen heeft u 1 of 2 extra mensen nodig.*
- (ES) *Notas importantes para el montaje: Estas instrucciones muestran el montaje de la caseta "AvantGarde" en tamaño XXL.< Es recomendable realizar el montaje entre dos o tres personas.*
- (IT) *Indicazioni importanti per il montaggio! Le seguenti istruzioni di montaggio fanno riferimento all'assemblaggio di „AvantGarde“ misura „XXL“. Per alcune fasi di assemblaggio vi serviranno 1 - 2 aiutanti.*



## Um Kratzer zu vermeiden, verwenden Sie bitte geeignete Unterlagen!

- (GB) *Please use a suitable underlay to avoid scratches!*
- (FR) *Pour éviter les rayures, utilisez les supports appropriés!*
- (NL) *Om krassen te voorkomen raden wij u aan er iets onder te leggen!*
- (ES) *Por favor, coloque en el suelo una base protectora adecuada para evitar posibles arañazos.*
- (IT) *Utilizzare una base adatta per evitare graffi!*



## Schraubverbindungen grundsätzlich erst am Ende der Montage festziehen!

- (GB) *Nuts not to be tightened before the end of assembly!*
- (FR) *Ne serrer les écrous à fond qu'à la fin du montage!*
- (NL) *Schroeven pas aan het einde van de montage vastdraaien!*
- (ES) *En principio, no apriete fijamente las tuercas hasta que no haya terminado de montar la caseta.*
- (IT) *I dadi devono essere serrati a fondo soltanto alla fine del montaggio!*

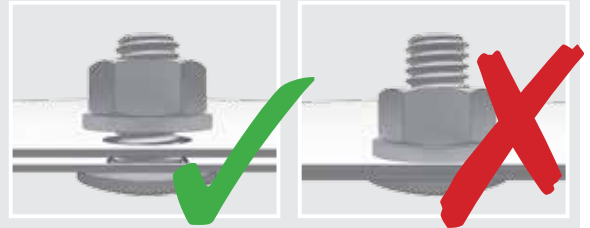

## Einbaumöglichkeiten der Türen anstelle von Wandelementen!

- (GB) *The door can be installed instead of a side wall element!*
- (FR) *La porte peut être installée sur le côté à la place d'une paroi latérale !*
- (NL) *Inbouwmogelijkheden van de deuren i.p.v. de wandelementen*
- (ES) *Es posible colocar las puertas en lugar de los paneles laterales.*
- (IT) *Considerare la possibilità di montare una porta standard al posto di una parete laterale!*

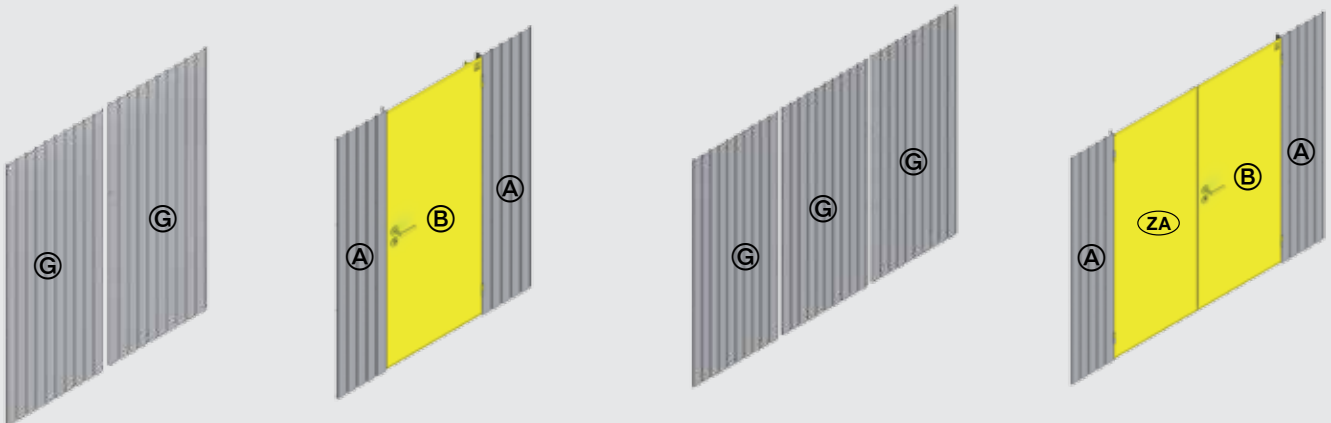



## Nicht bei Wind aufbauen!

(GB) Do not assemble the shed on a windy day!

(FR) Ne pas assembler quand il y a du vent !

(NL) Niet bij wind opbouwen!

(ES) No monte la caseta si hace mucho viento.

(IT) Non montare la casetta in giornate di vento!



## Verwenden Sie bei der Montage Arbeitshandschuhe!

(GB) Wear working gloves!

(FR) Portez des gants de travail

(NL) Handschoenen gebruiken!

(ES) Utilice unos guantes de trabajo.

(IT) Utilizzare guanti da lavoro



## Optionales Zubehör - Symbol:

Arbeitsschritte, die blau eingerahmt sind, zeigen den Einbau eines optionalen Zubehörteiles.

(GB) Symbol of optional accessories: Blue framed assembly steps show the installation of optional accessories.

(FR) Accessoires en option-Symbole: La trame entourée en bleu indique une étape avec accessoires en option. À réaliser uniquement si vous avez commandé cet accessoire.

(NL) Extra Toebehoor: Montageschappen met een blauwe rand betreffen de inbouw van extra toebehoor.

(ES) Accesorio opcional - símbolo: Los pasos de montaje que se encuentran enmarcados en azul muestran el montaje de una pieza de un accesorio opcional.

(IT) Simbolo per accessori opzionali: Le fasi del montaggio incorniciate in colore azzurro mostrano l'installazione di un accessorio opzionale.



optionales Zubehör - Accesso...

## Bodenrahmen

(Floor Frame - Cadr)



## Wasserwaagen - Symbol:

Betreffendes Einbauteil mit der Wasserwaage ausrichten.

(GB) Symbol of spirit level: Align the respective parts by using the spirit level.

(FR) Symbole niveau à bulle: Lorsque ce symbole apparaît, vous devez ajuster l'élément à l'aide d'un niveau à bulle.

(NL) Waterpas - symbol: Bij montageschappen waar dit symbool bijstaat is het noodzakelijk het betreffende onderdeel waterpas in te bouwen.

(ES) Símbolo del nivelador: Indica que se debe ajustar y centrar la pieza con la ayuda de un nivelador.

(IT) Simbolo di livella a bolla d'aria: Allineare il componente in questione con l'ausilio di una livella a bolla d'aria.

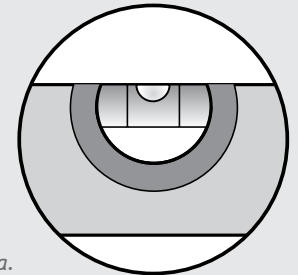

## Maßstabsgetreue Abbildung der zu verwendenden Schrauben:!

(GB) Scale drawing 1:1 of the screws in use

(FR) Reproduction selon l'échelle 1:1.

(NL) Afbeelding : schaal 1:1 (ware grootte)

(ES) Reproducción a escala 1:1 de los tornillos que se utilizan para el montaje.

(IT) Immagine in scala delle viti da utilizzare!

### M 1:1



4,8 x 9,5



4,8 x 13



M5 x 12



M4 x 10



M4 x 18



M5 x 10

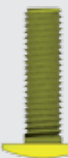

M5 x 18

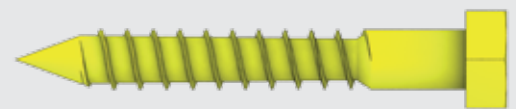

8 x 60

## Pflege und Wartung

- Keine aggressiven Chemikalien wie z.B. Chlor oder Streusalz offen lagern!
- Sonnenmilch und andere Cremes mit Wasser und Seife entfernen
- Keine scheuernden Reinigungsmittel verwenden!
- Laub vom Dach regelmäßig entfernen!
- Dachrinnenauslauf kontrollieren
- Tiefe Kratzer sofort mit beiliegendem Lack ausbessern!
- Ölen Sie das Schloss jährlich!

### EN Care and maintenance

- Do not store aggressive substances uncovered i.e. chlorine or road salt
- Remove suntan lotion or any other creams with water and rinse aid!
- Do not use abrasive cleaning agents!
- Keep the roof free of leaves!
- Check the gutter
- Touch-up scratches immediately with the paint provided.
- Lubricate the lock once a year!

### FR Entretien et maintenance

- Ne pas stocker de produits chimiques (chlore, sel, etc...)
- Nettoyez uniquement avec de l'eau les crèmes solaires et autres crèmes (pas de nettoyage chimique).
- Ne pas utiliser de produits nettoyant abrasifs!
- Débarrassez vous régulièrement des feuilles mortes sur le toit !
- Corrigez immédiatement les rayures avec la laque jointe!
- Graissez la serrure et les charnières chaque année !

### NL Onderhoud

- Geen chemicaliën om de berging opslaan
- Zonnebrandolie/melk en andere cremes met water en glansmiddel verwijderen
- Gebruik geen schuurmiddelen!
- Regelmatig bladeren van dak verwijderen!
- Krassen direct met de meegeleverde lak behandelen
- Slot jaarlijks oliën

### ES Cuidado y mantenimiento

- No almacene productos químicos agresivos dentro de la caseta como por ejemplo cloro y sal antiescarcha.
- Evite dejar huellas o restos de cremas solares sobre la chapa. Limpie la caseta siempre con agua o un trapo húmedo.
- No utilice ningún producto para fregar. En general, evite siempre cualquier producto químico para limpiar la caseta.
- Mantenga el tejado libre de hojas secas.
- Repare los arañazos lo antes posible con el barniz que se incluye
- Aplique aceite en la cerradura y las bisagras una vez al año

### IT Manutenzione

- Non lasciare prodotti chimici aggressivi (come ad esempio cloro o sale per strade) all'interno della casetta!
- Rimuovere crema solare e altre creme con acqua e brillantante!
- Non utilizzare detergenti contenenti sostanze aggressive!
- Mantenere il tetto libero da foglie!
- Ritoccare immediatamente eventuali graffi con la vernice fornita nella confezione!
- Lubrificare la serratura e le cerniere a cadenza annuale!

## Vorschläge für das Fundament

Bitte achten Sie bei der Fundamentgestaltung darauf, dass Niederschlagswasser nicht seitlich unter den Bodenprofilen in das Gerätehaus eindringen kann! (siehe Varianten 1, 2, 3). Aufsteigende Bodenfeuchtigkeit und Kondensation vermeiden Sie mittels einer starken Kunststoffolie unter dem Fundament.

### GB *Proposals for a secure foundation*

When making the foundation arrangements please take necessary precaution to ensure that water cannot leak in under the floor profiles (see option 1, 2, 3). Rising ground moisture and condensation can be avoided by using a strong plastic sheet underneath the paving slabs or underneath the concrete foundation.

### FR *Conseils pour les fondations*

Lors de la réalisation de la fondation, veillez à ce que l'eau de pluie ne puisse pas pénétrer dans l'abri ou par les côtés sous les profils de sol (voir variantes 1,2,3). Vous pouvez éviter l'humidité du sol et la condensation en mettant un film plastique épais sous les plaques de béton.

### NL *Voorstellen voor fundament*

Let er bij het maken van de fundering op dat regenwater niet onder het bodemprofiel kan doorlopen (zie voorbeeld 1,2,3). Een vochtige bodem en condensatie kunt u vermijden door het aanbrengen van een sterke kunststoffolie onder de tegels of het betonfundament.

### ES *Medidas y recomendaciones para los cimientos:*

Al colocar los cimientos, asegúrese de que el agua de lluvia no puede penetrar en la caseta por los laterales debajo del perfil del suelo (véase variante 1,2 y 3). Evite la humedad y la condensación en el suelo colocando una lámina de plástico bajo las losas o los cimientos de hormigón.

### IT *Proposte per il basamento:*

Il basamento deve essere progettato in modo da evitare infiltrazioni di acqua piovana all'interno della casetta (vedere proposta 1-2-3). Un telo di plastica spesso posto in corrispondenza dell'area di pavimento evita infiltrazioni di umidità dal terreno e la formazione di condensa.



Weitere Details betreffend Fundament finden Sie auch unter [www.biohort.com/Fundament](http://www.biohort.com/Fundament)  
Further details about foundations you will find on [www.biohort.com/foundation](http://www.biohort.com/foundation)  
Pour détails supplémentaires veuillez consulter [www.biohort.com/foundations](http://www.biohort.com/foundations)  
Verdere details over het fundament vindt u ook op [www.biohort.com/fundament](http://www.biohort.com/fundament)

# Maße für das Fundament

- (GB) Foundation dimensions
- (FR) Dimensions pour la fondation
- (NL) Maat voor het fundament
- (ES) Medidas de los cimientos
- (IT) Dimensioni del basamento

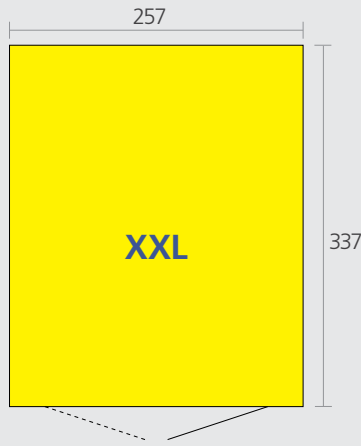

Zusatztür Positionen - Side door positions - Positione de porte suplémentaire - Extra deur positie - Posición puerta adicional - Posizione della porta aggiuntiva

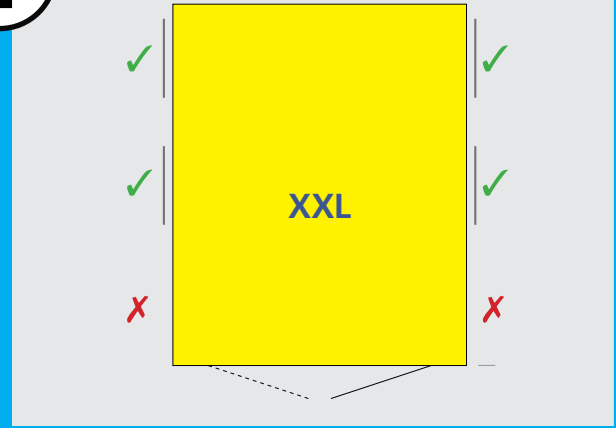

**ACHTUNG** ATTENTION  
ATTENTION | ATTENTIE |  
LET OP | ATENCIÓN |  
ATTENZIONE



Die Verankerung ist wichtig, denken Sie an Sturmböen!  
Do not forget to anchor the shed against gale force wind!

L'ancrage est important, pensez aux rafales de vent!

Verankering niet vergeten!

El anclaje es muy importante. Piense por ejemplo en rachas fuertes de viento.

L'ancoraggio della casetta è importante - pericolo in caso di raffiche di vento!

## Variante, Proposal, Variant 1

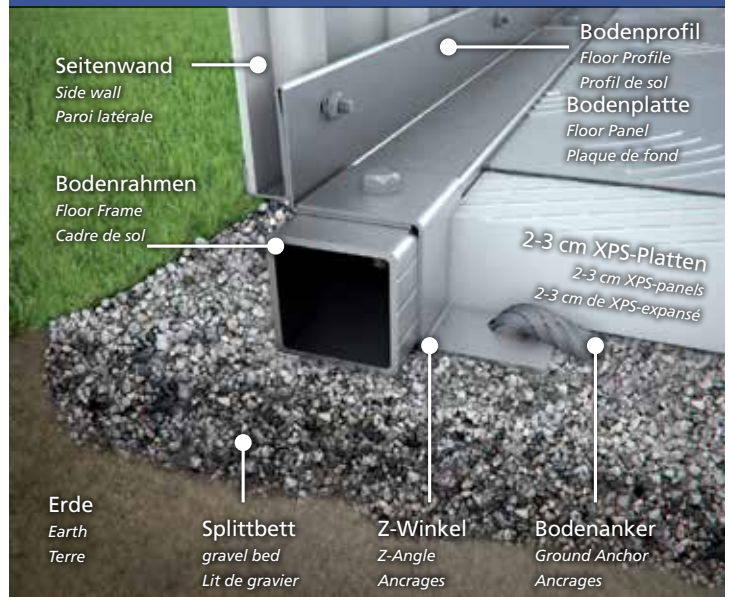

## Variante, Proposal, Variant 2

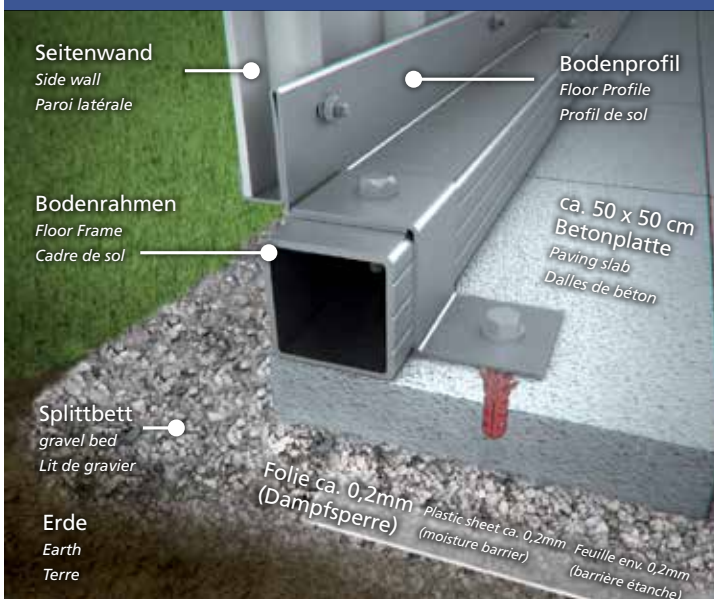

## Variante, Proposal, Variant 3

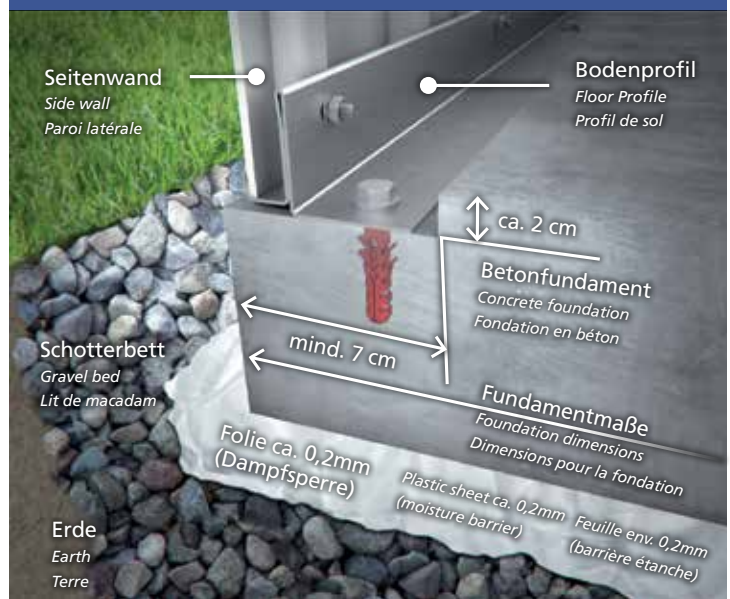



**1 Paket Nr. 1**  
 Türpaket · doorpackage · carton de portes · deurpakket · pacco pareti laterali · kit de puerta

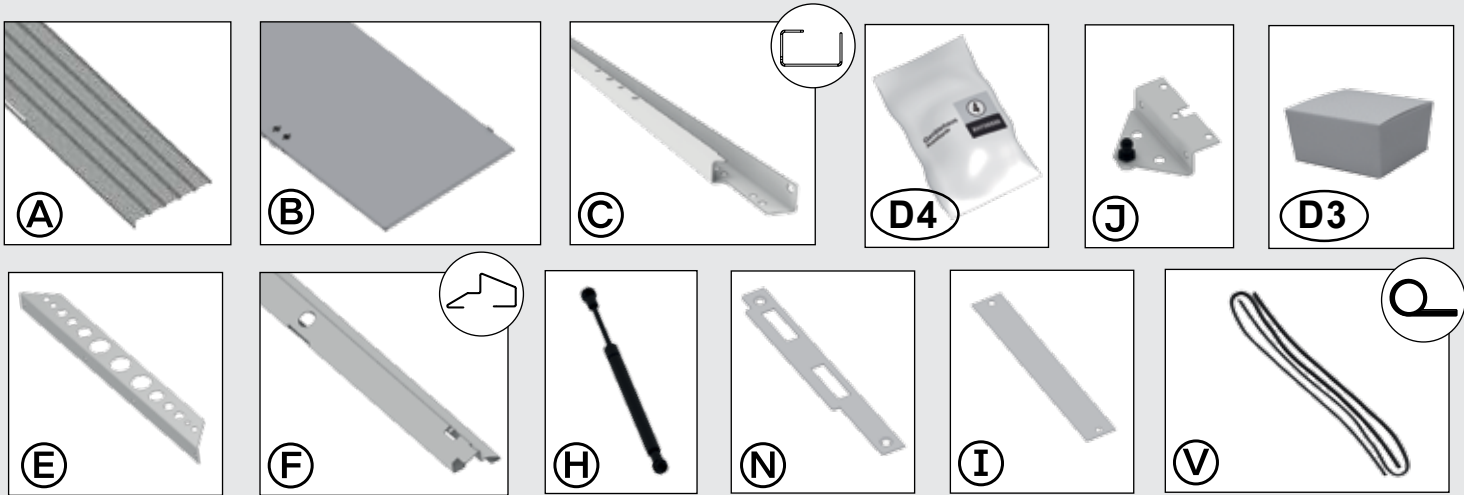

**Teil ③ entfällt bei der Doppeltür**

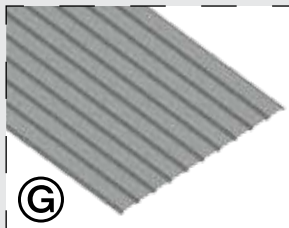

- ③ GB Part ③ not required when double doors are fitted
- ③ FR La pièce est supprimée pour la double portes.
- ③ NL Deel ③ vervalt bij de dubbele deur
- ③ ES pieza ③ no es necesaria en caso de puerta doble
- ③ IT Pezzo ③ non può essere utilizzato per la variante porta a due battenti

**Zusatzteile Doppeltür**

( double door package · carton de double portes · dubbeldeurpakket · pacco porta doppia · kit de puerta adicional )

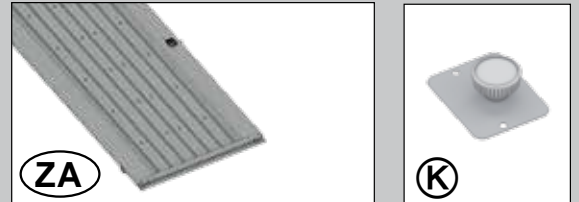

**2 Paket Nr. 2**  
 Seitenwandpaket · side panel package · carton de parois latérales · zijwandpakket · pacco pareti laterali · panel lateral



**3 Paket Nr. 3**  
 Profilpaket · profile package · carton de profils · profielpakket · pacco profili · kit de perfiles

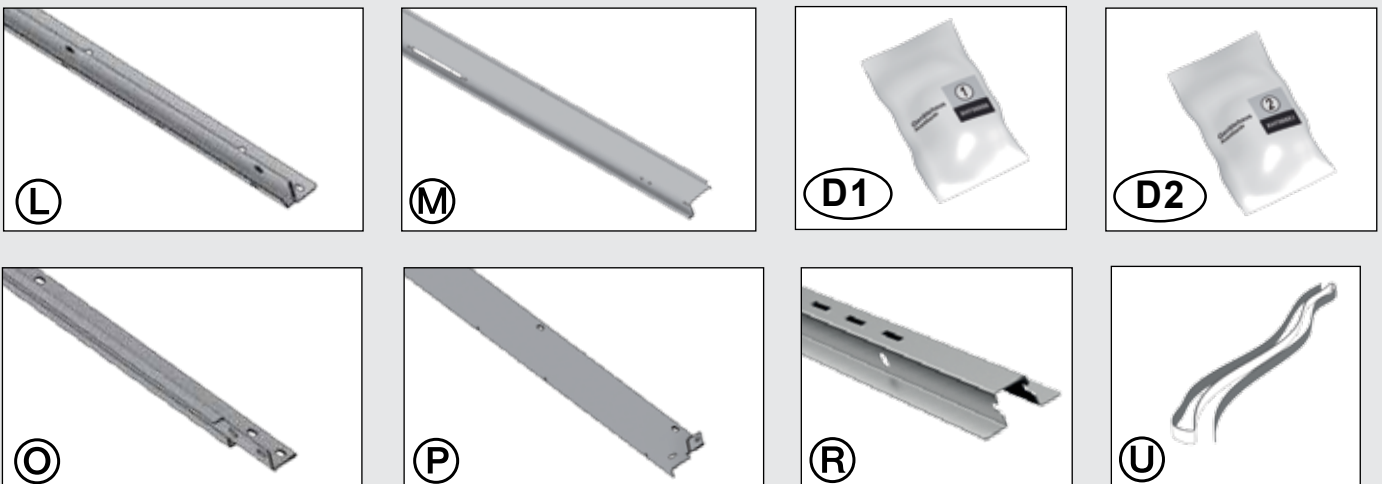

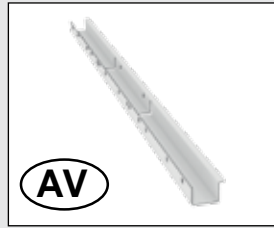
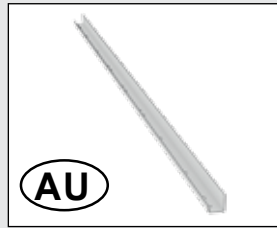
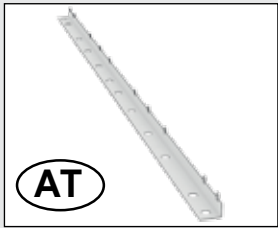
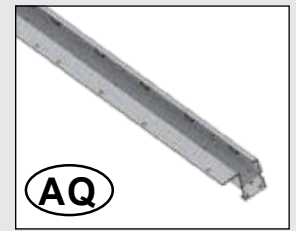
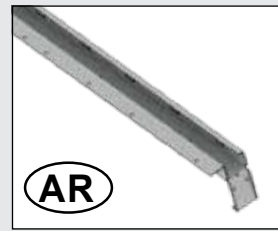
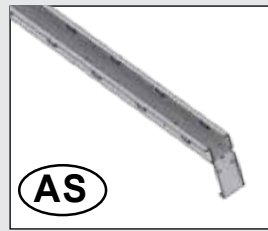
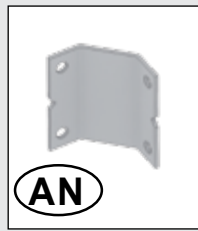
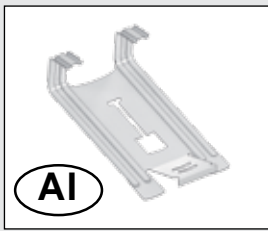

#### 4 Paket Nr. 4

Dach-Blechpaket · roof panel package · carton de tôles de toit · dakplaatpakket · pacco lamiera tetto · kit de tejado laminado

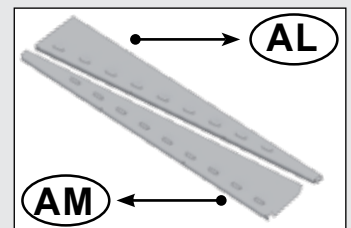
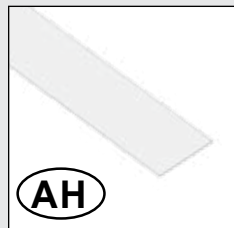
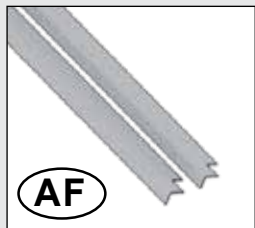
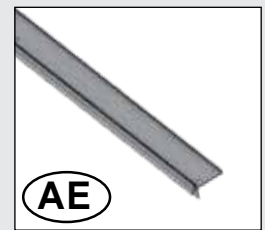
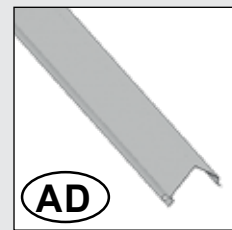
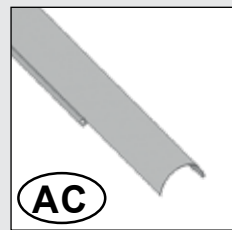
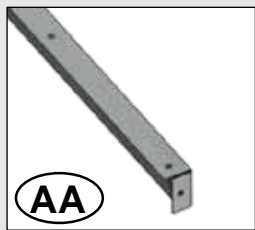
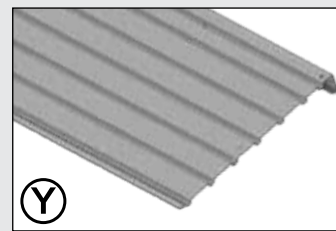
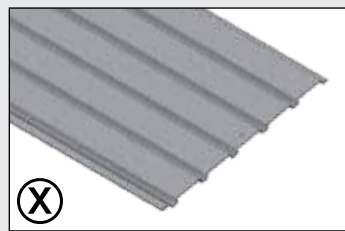

#### 5 Paket Nr. 5



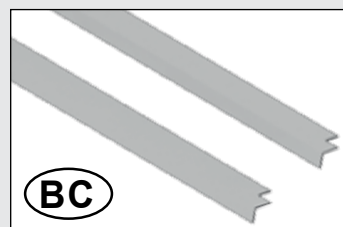
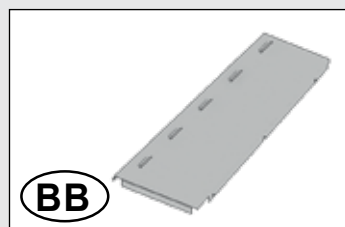
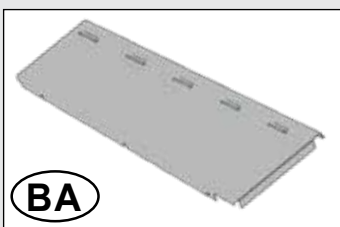
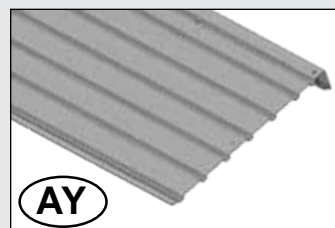
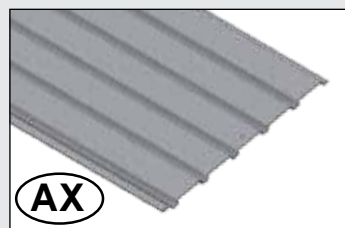



Dach-Zusatzpaket · roof panel additional package · carton supplémenta de tôles de toit · Extra dakplaatpakket · pacco aggiuntivo lamiera tetto · kit adicional de tejado laminado

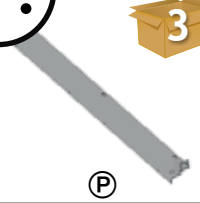

# Rückwand

(Rear wall - Paroi arrière - Achterwand - panel posterior - Parete posteriore)

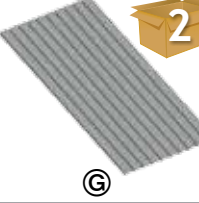
1.

 Ⓟ	 1x (2510mm)	 Ⓛ	 1x (2510mm)	 Ⓞ	 3x
M5 x 10  ⓓ2	8x				

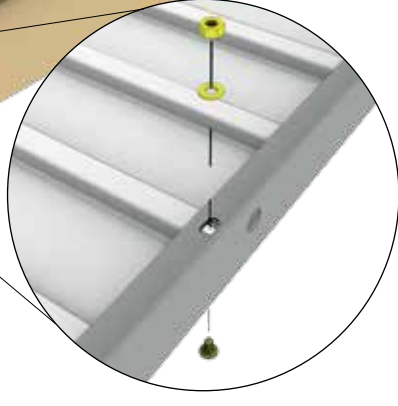
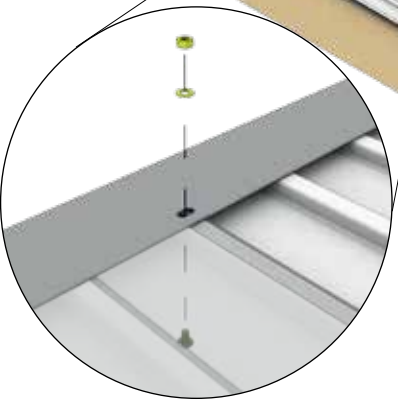
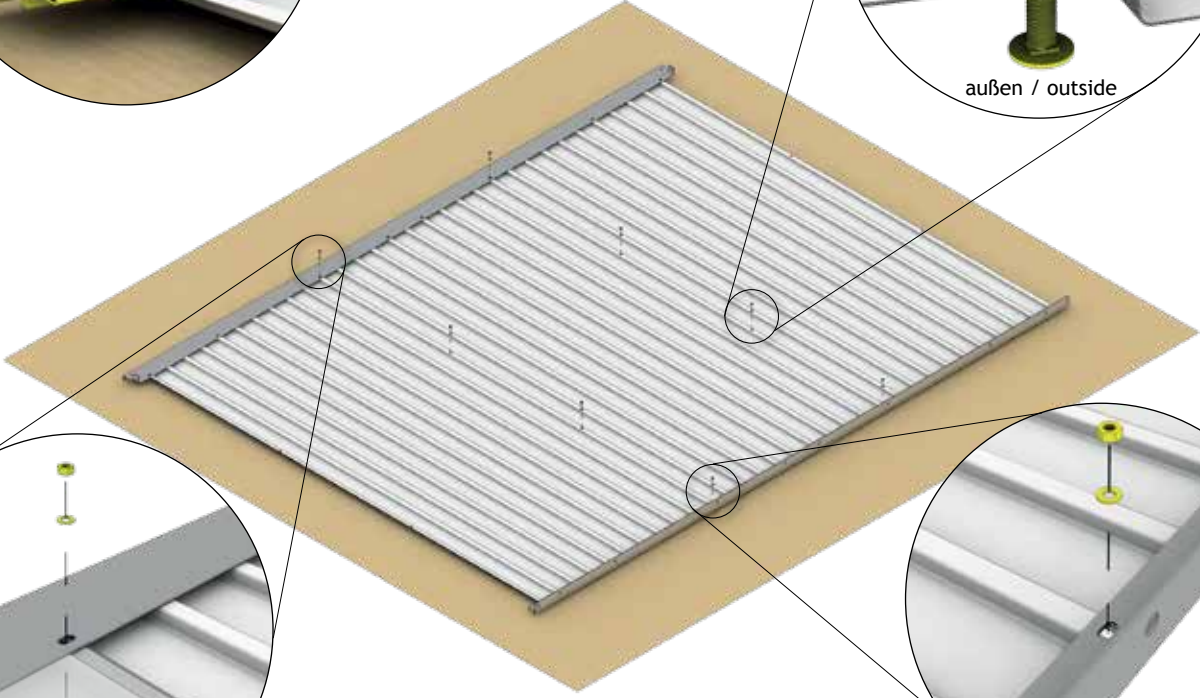
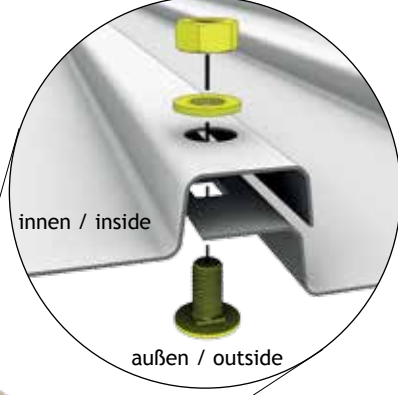
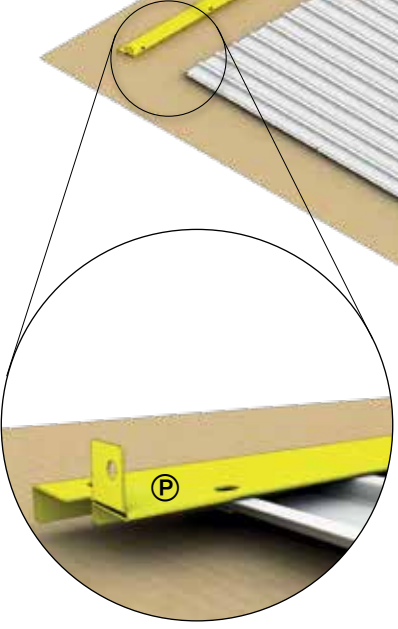
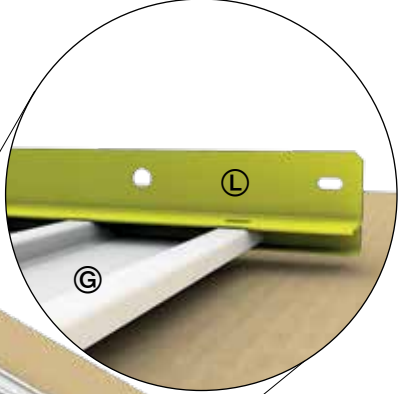
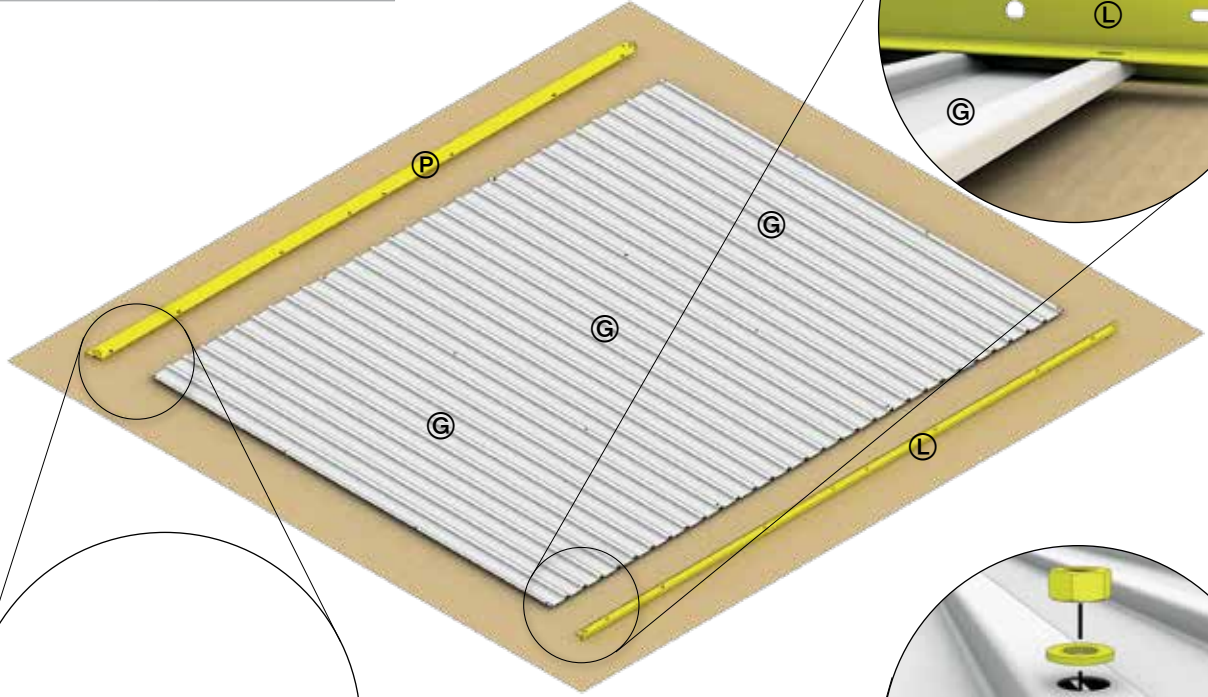







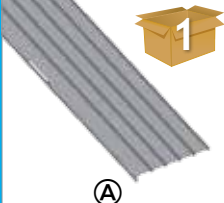

## Doppeltür

(Double Door - Deuxième battant de porte - Tweede deurvleugel - Secondo battente - puerta doble)

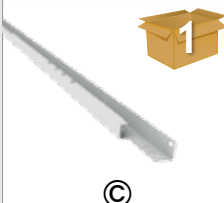

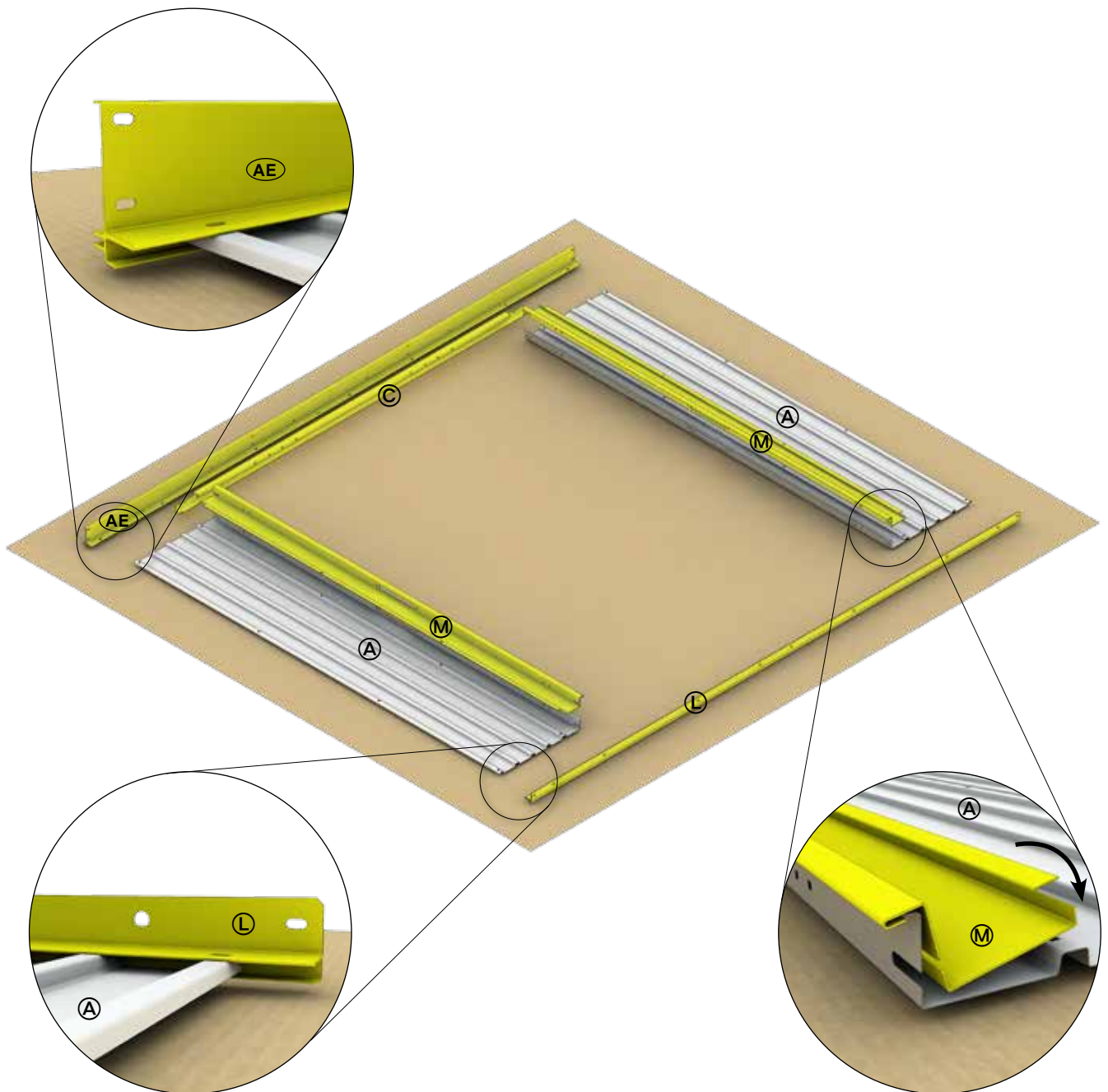







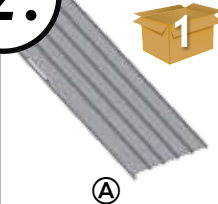

 <p>1 2x A</p>	 <p>4 1x (2510mm) AE</p>	 <p>3 2x M</p>
 <p>3 1x (2510mm) L</p>	 <p>1 1x (1784mm) C</p>	



# Türwand

(Door wall - Paroi de la porte - Deurwand - panel de puerta - Parete con porta)

2.

 A	 2x	 AE	 1x (2510mm)	 M	 2x
 L	 1x (2510mm)	 G	 1x	 C	 1x (984mm)

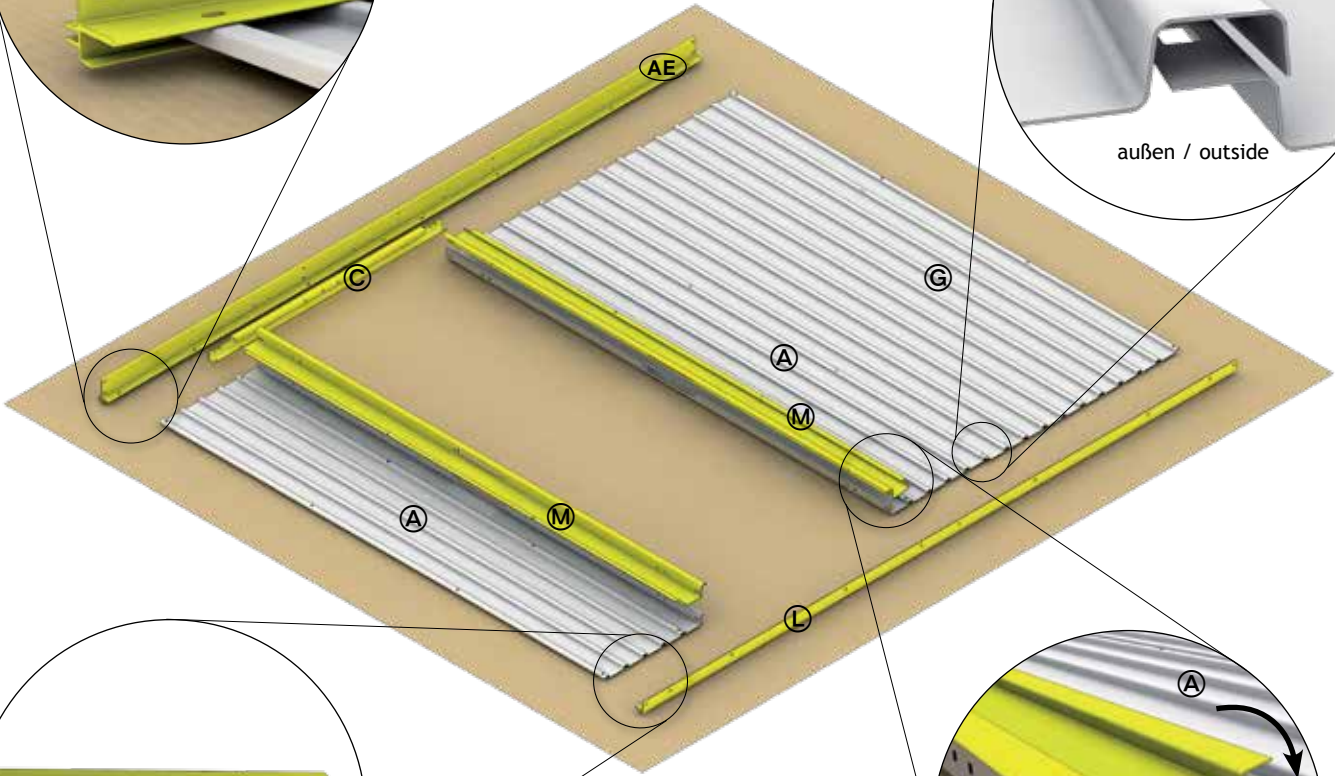
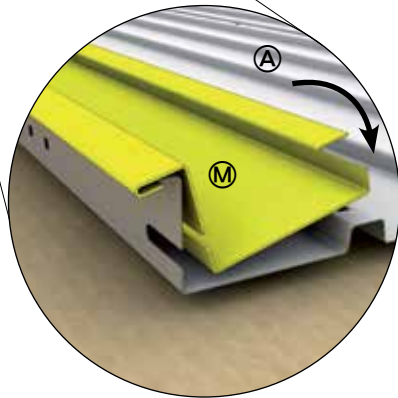
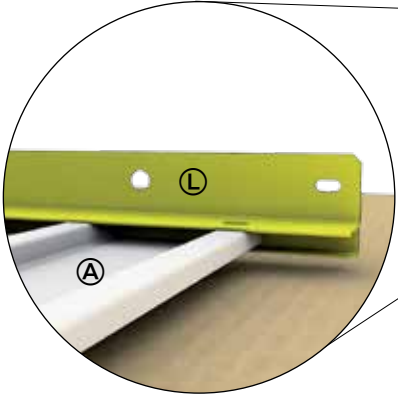
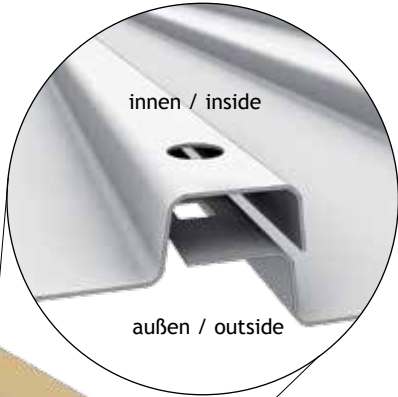
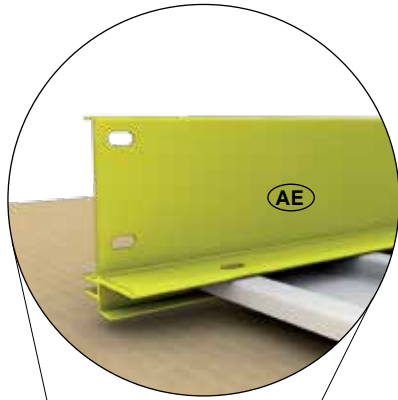

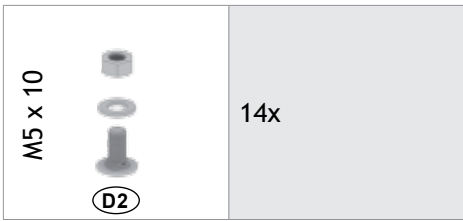

<h2 style="margin: 0;">Doppeltür</h2> <p style="margin: 0; font-size: small;">(Double Door - Deuxième battant de porte - Tweede deurvleugel - Secondo battente - puerta doble)</p>	<table border="1"> <tr> <td style="vertical-align: top;">M5 x 10</td> <td style="text-align: center;"> </td> <td style="vertical-align: top;">12x</td> </tr> <tr> <td></td> <td style="text-align: center;">D2</td> <td></td> </tr> </table>	M5 x 10		12x		D2	
M5 x 10		12x					
	D2						

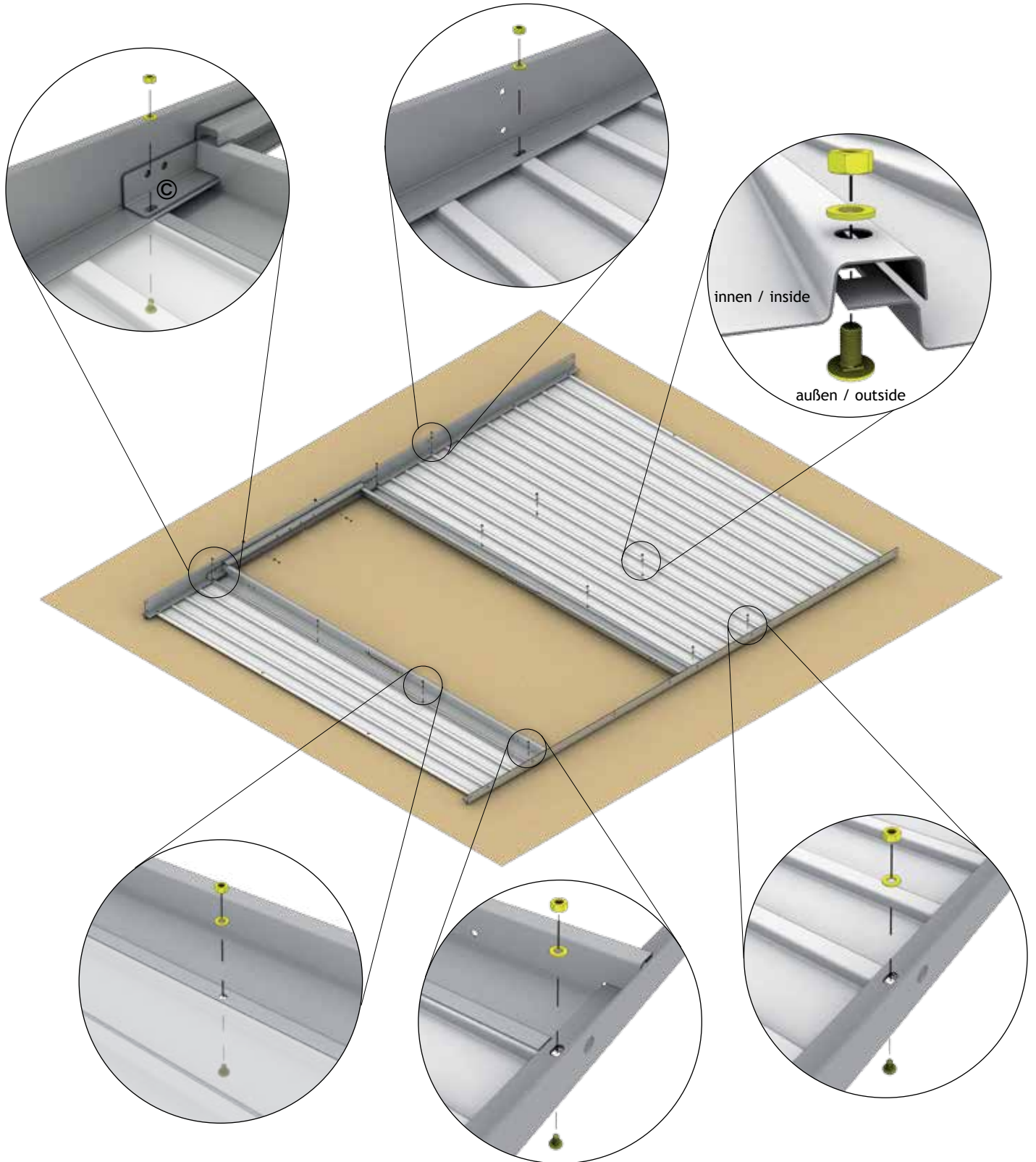







# Seitenwand

(Side wall - Paroi latérale - Zijwand - panel lateral - Parete laterale)

3.

 <p>ⓐ</p>	<p>3</p> <p>2x (2510mm)</p>	 <p>Ⓛ</p>	<p>3</p> <p>2x (2510mm)</p>	 <p>ⓐ</p>	<p>2</p> <p>6x</p>
<p>M5 x 10</p>  <p>ⓓ2</p>	<p>8x</p>				

2x

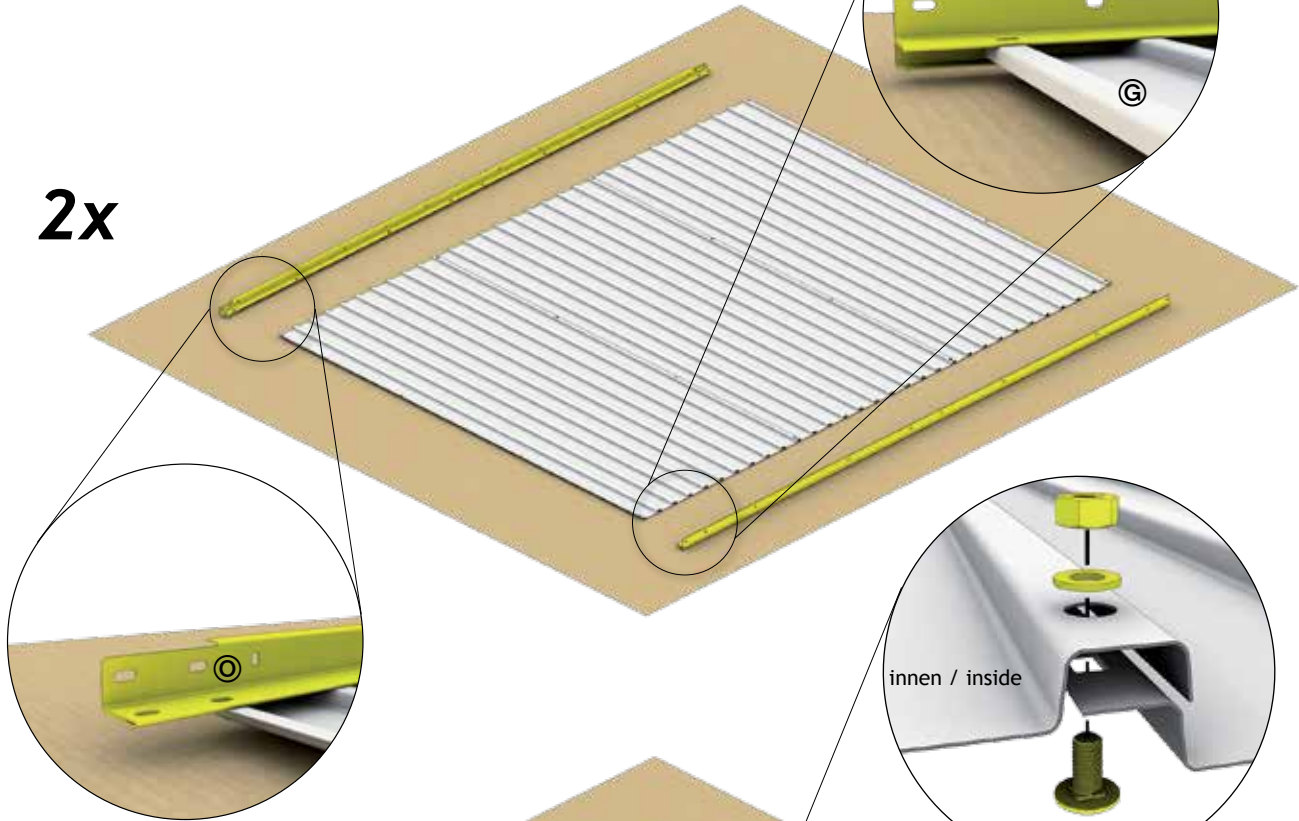

2x

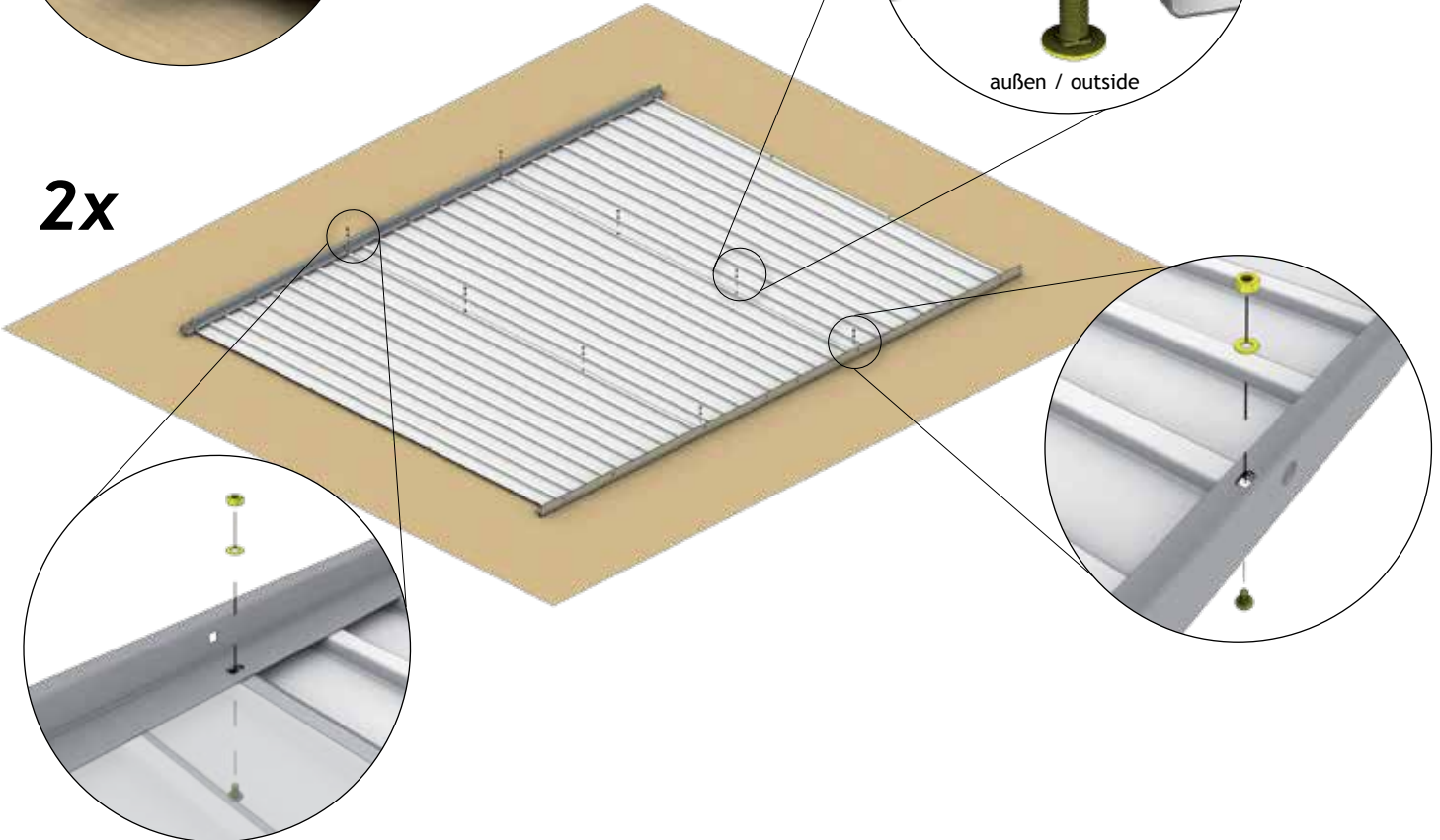









# Bodenrahmen

(Floor Frame - Cadre de sol - Telaio perimetrale - Bodemframe - marco de suelo)

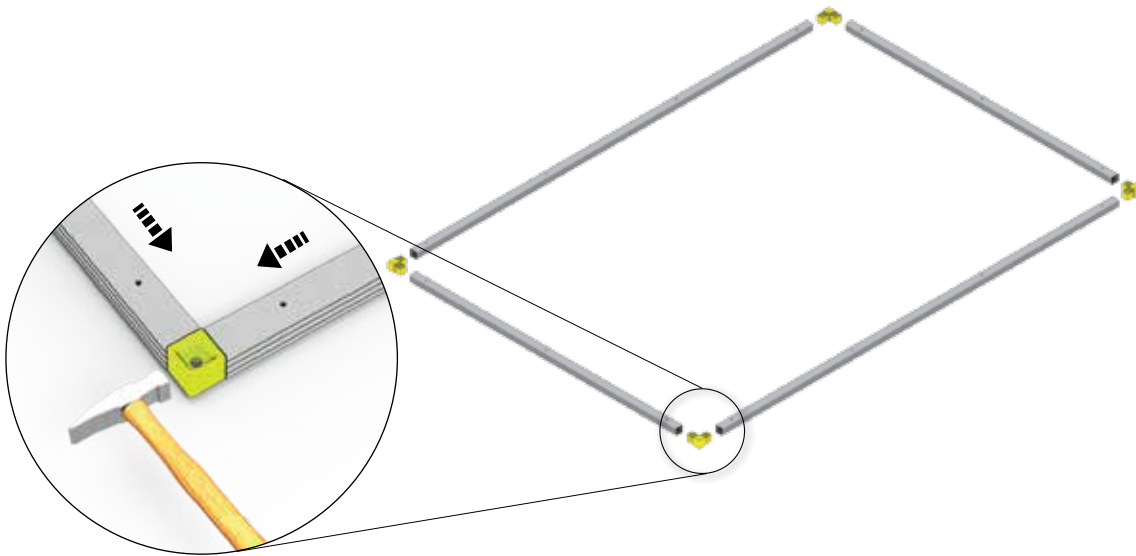
 <p>(ZB)</p>	<p>2x (2440mm) 2x (3240mm)</p>	 <p>(ZC)</p>	<p>4x</p>
--	------------------------------------	---	-----------



 <p>(ZD)</p>	<p>1x</p>	<p>6,3 x 22</p>  <p>(ZF)</p>	<p>1x</p>	<p>M5 x 10</p>  <p>(D2)</p>	<p>1x</p>
---	-----------	---	-----------	--	-----------

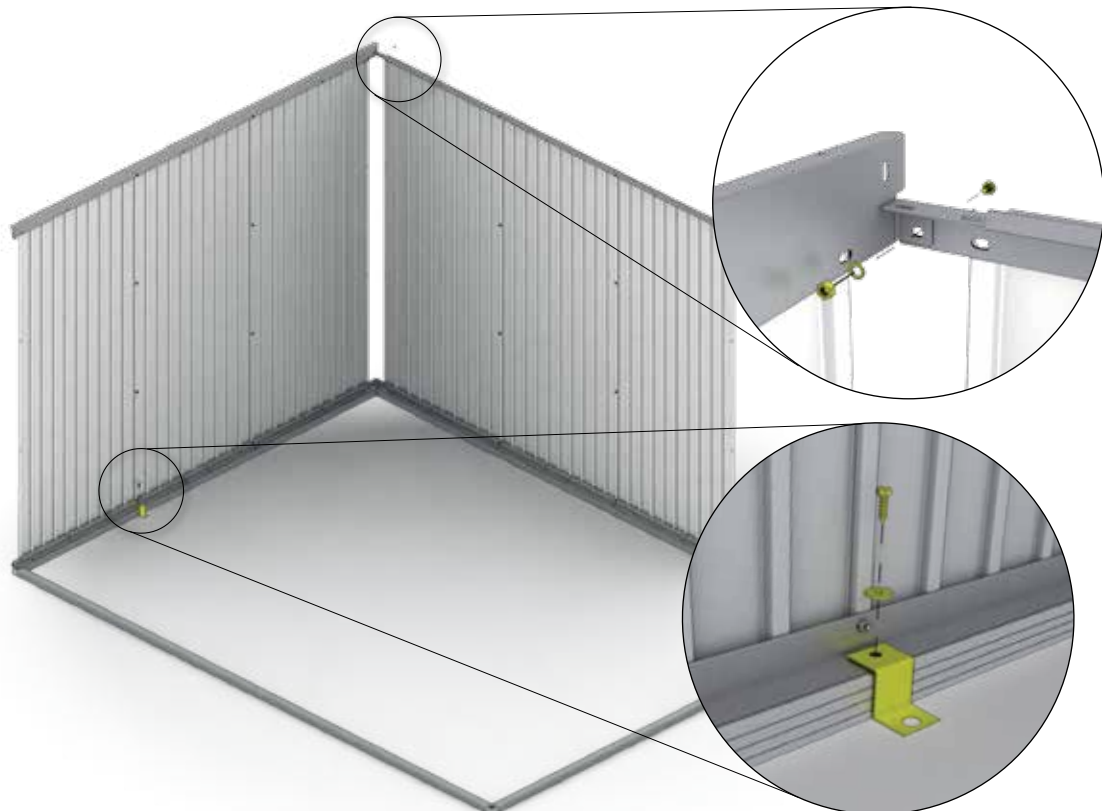



# Bodenrahmen

(Floor Frame - Cadre de sol - Telaio perimetrale - Bodemframe - marco de suelo)

<p><b>ZD</b></p>	<p>6x</p>	<p>M5 x 10</p> <p><b>D2</b></p>	<p>3x</p>	<p>6,3 x 22</p> <p><b>ZF</b></p>	<p>10x</p>
------------------	-----------	---------------------------------	-----------	----------------------------------	------------

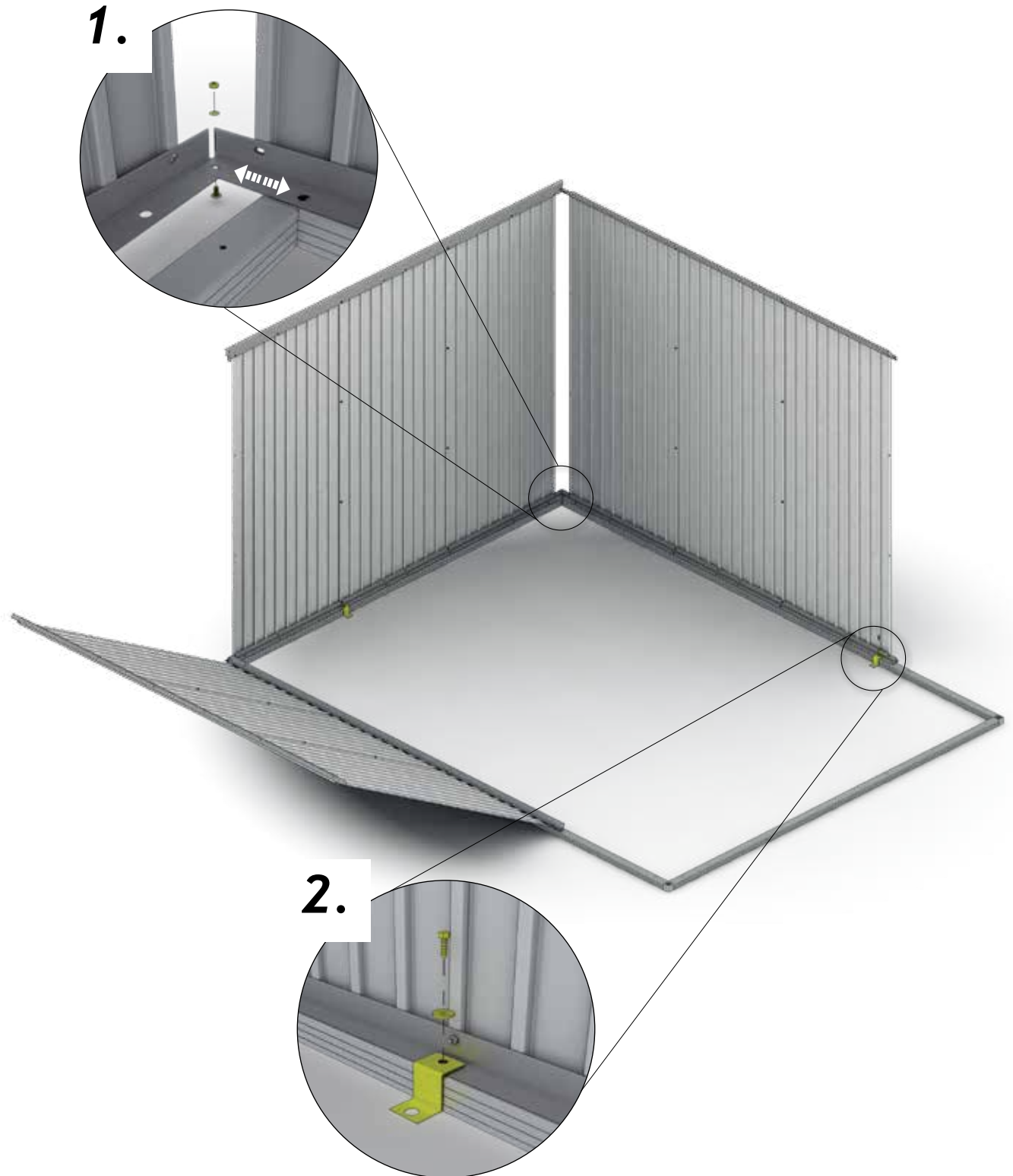

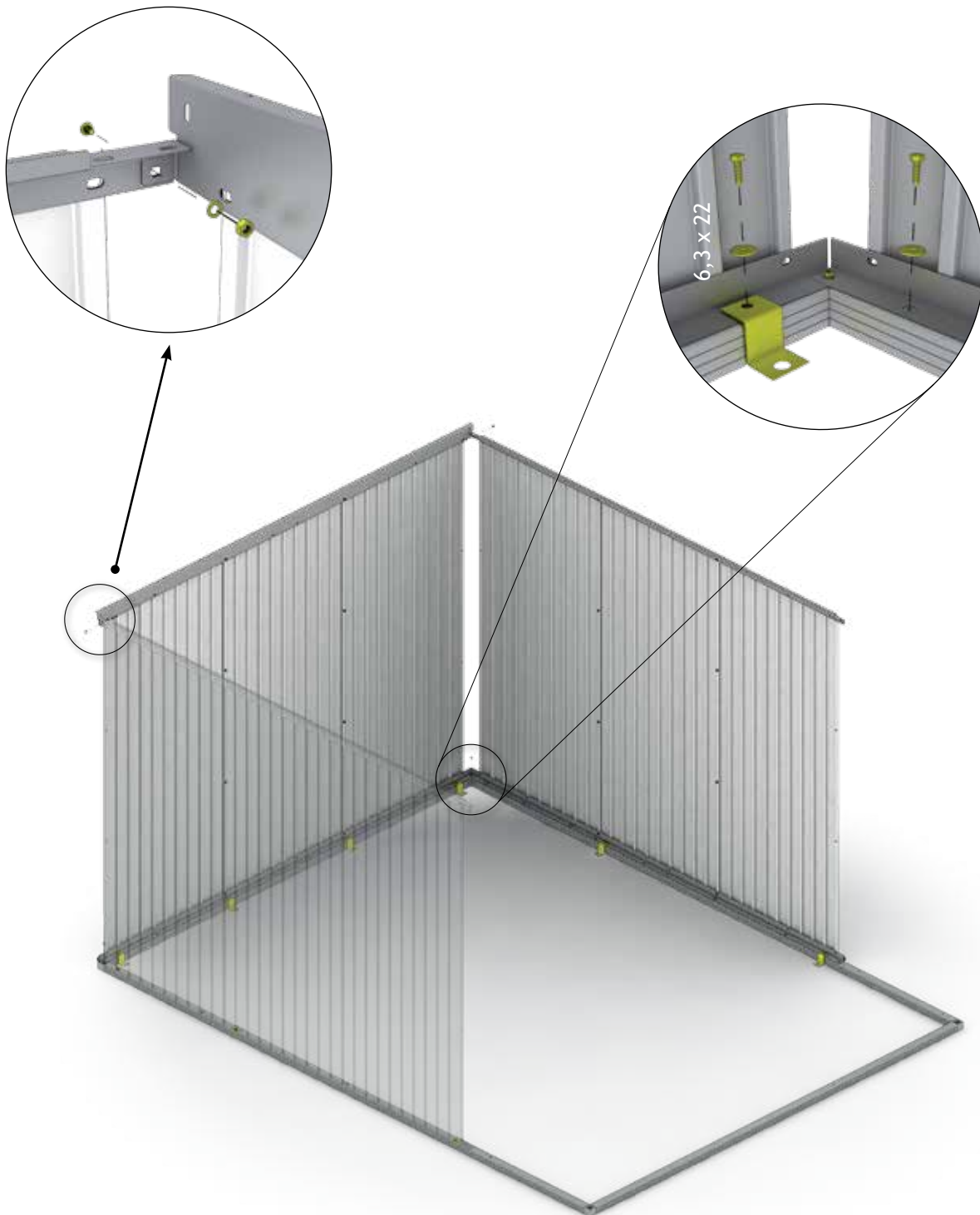

4.

M5 x 10





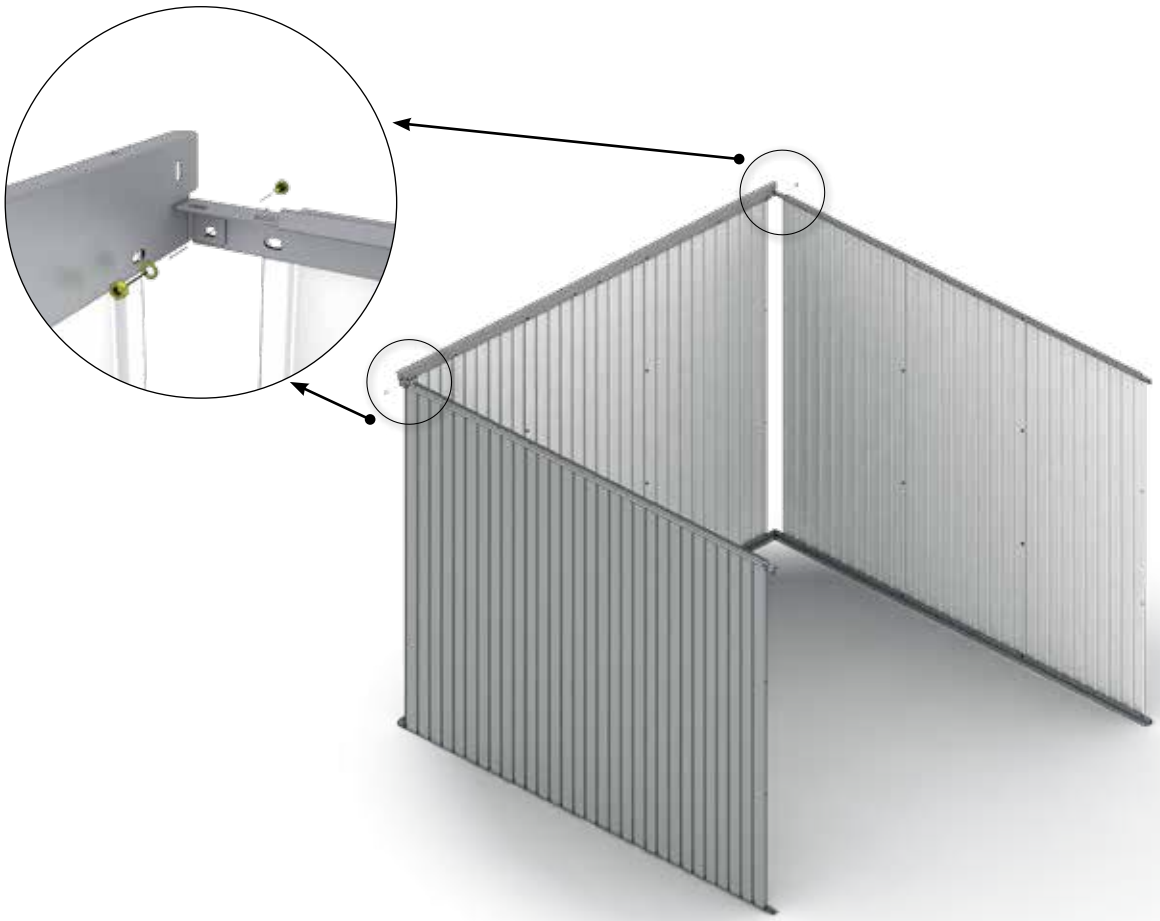
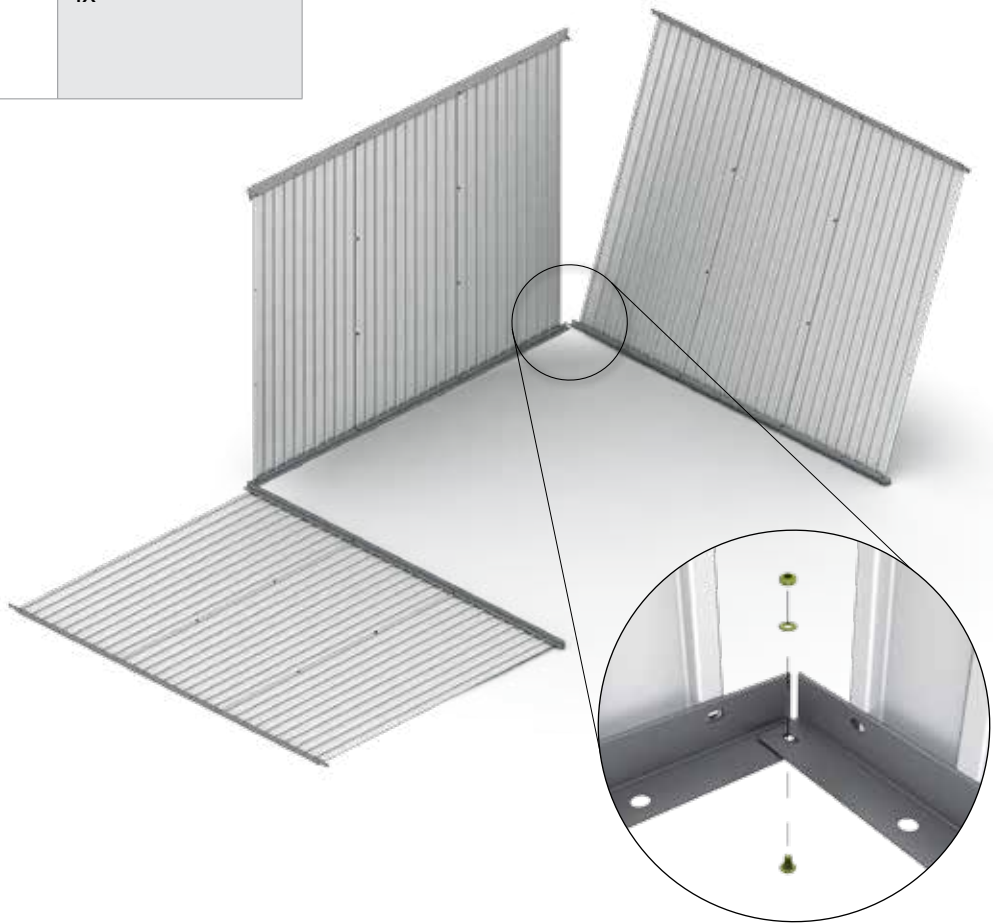

4x

D2



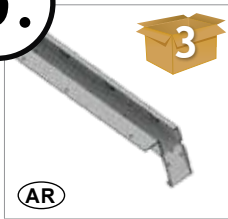

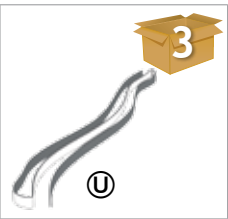

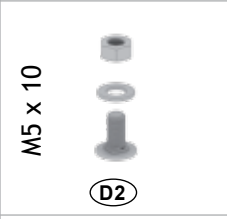
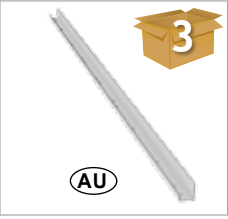
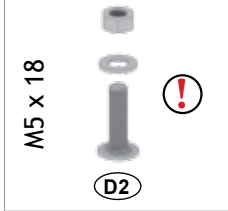
# 5.

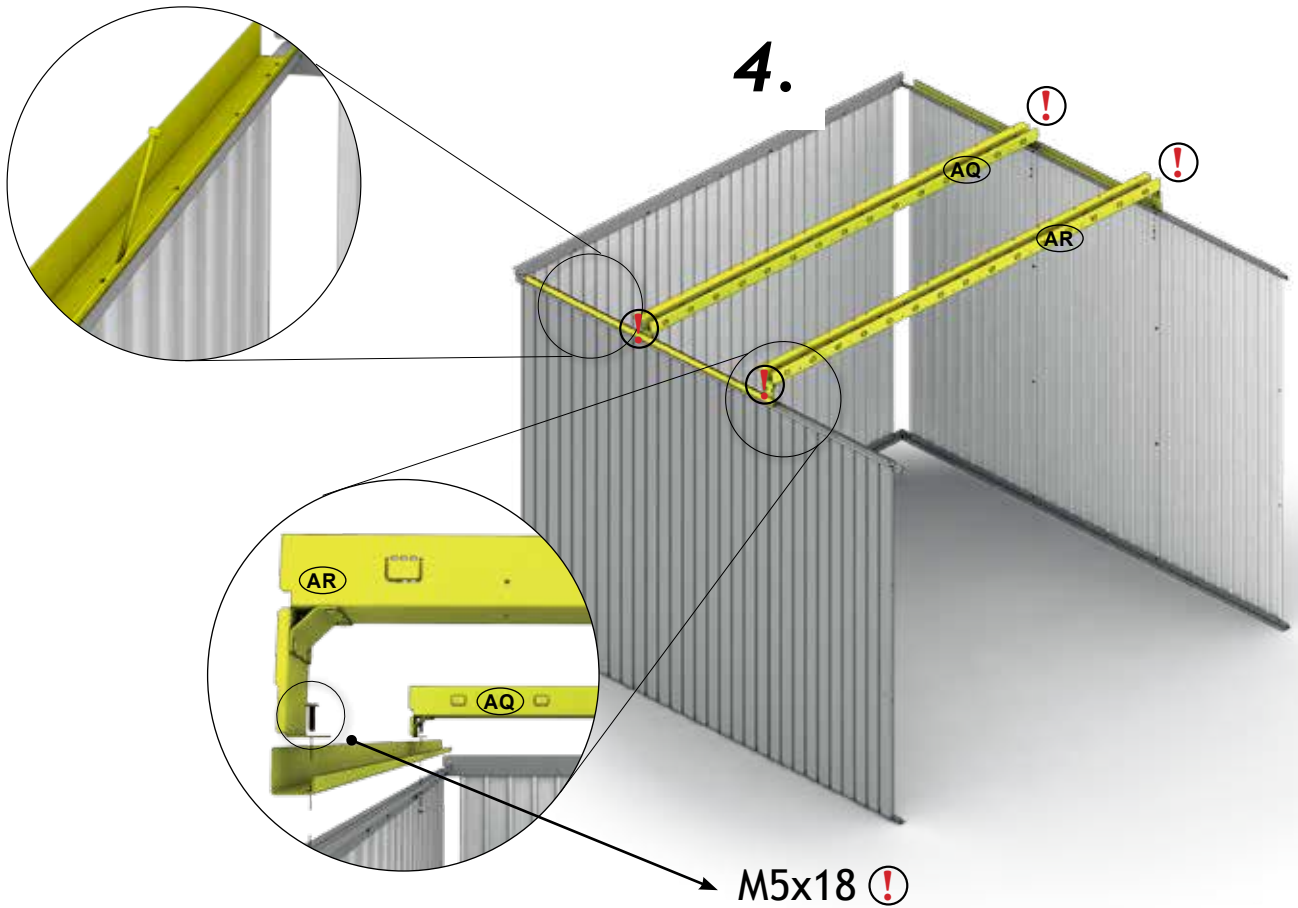
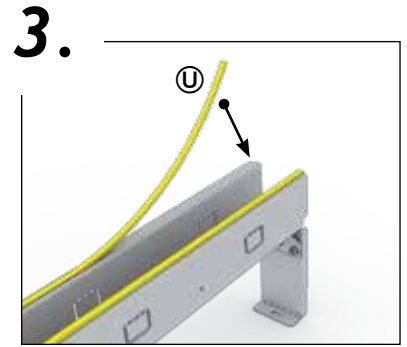
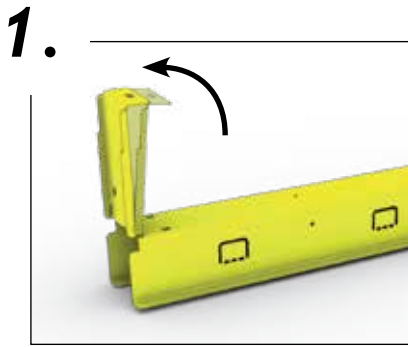
 <p>AR</p>	<p>1x (2530mm)</p>	 <p>AQ</p>	<p>1x (2530mm)</p>	 <p>U</p>	<p>1x</p>
 <p>AN</p>	<p>4x</p>	<p>M5 x 10</p>  <p>D2</p>	<p>16x</p>	 <p>AU</p>	<p>2x (1615mm)</p>
<p>M5 x 18</p>  <p>D2</p>	<p>4x</p>				

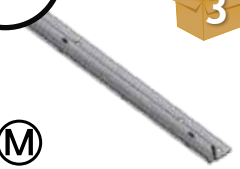

6.

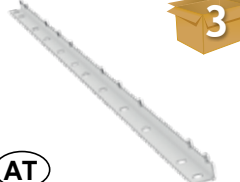
 <p>3 2X (800mm) M</p>	 <p>5 2X G</p>	<p>M5 x 10 D2 12x</p>
 <p>3 2X (1220mm) AT</p>		

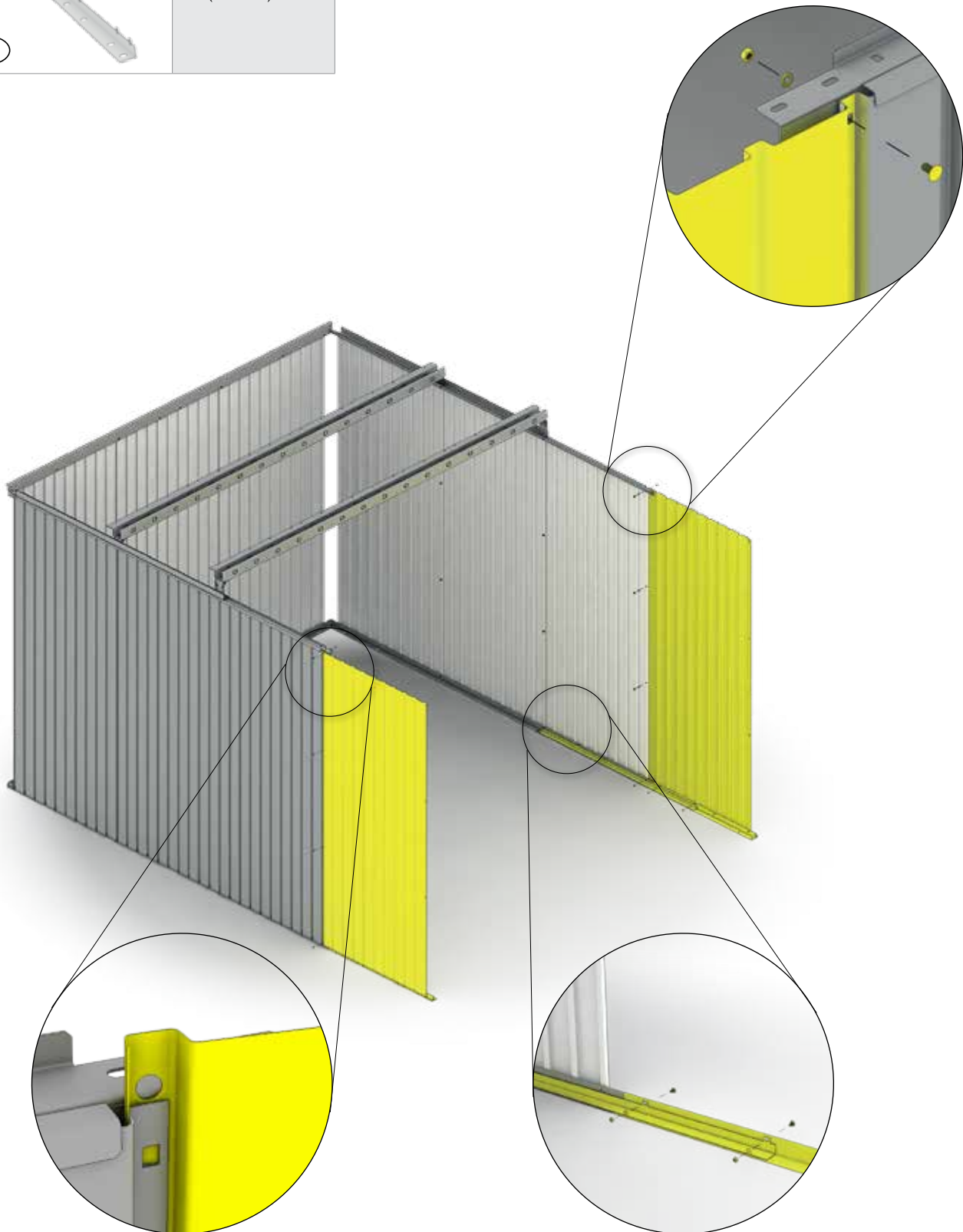

7.

3

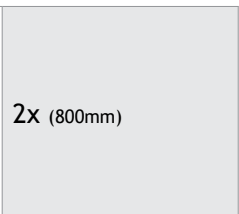

2x (800mm)

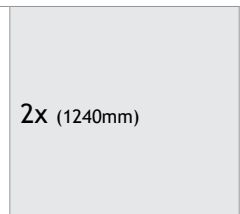

2x (1240mm)

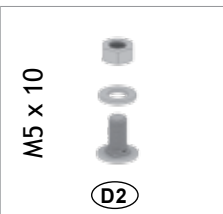



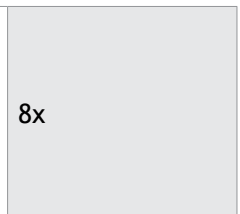

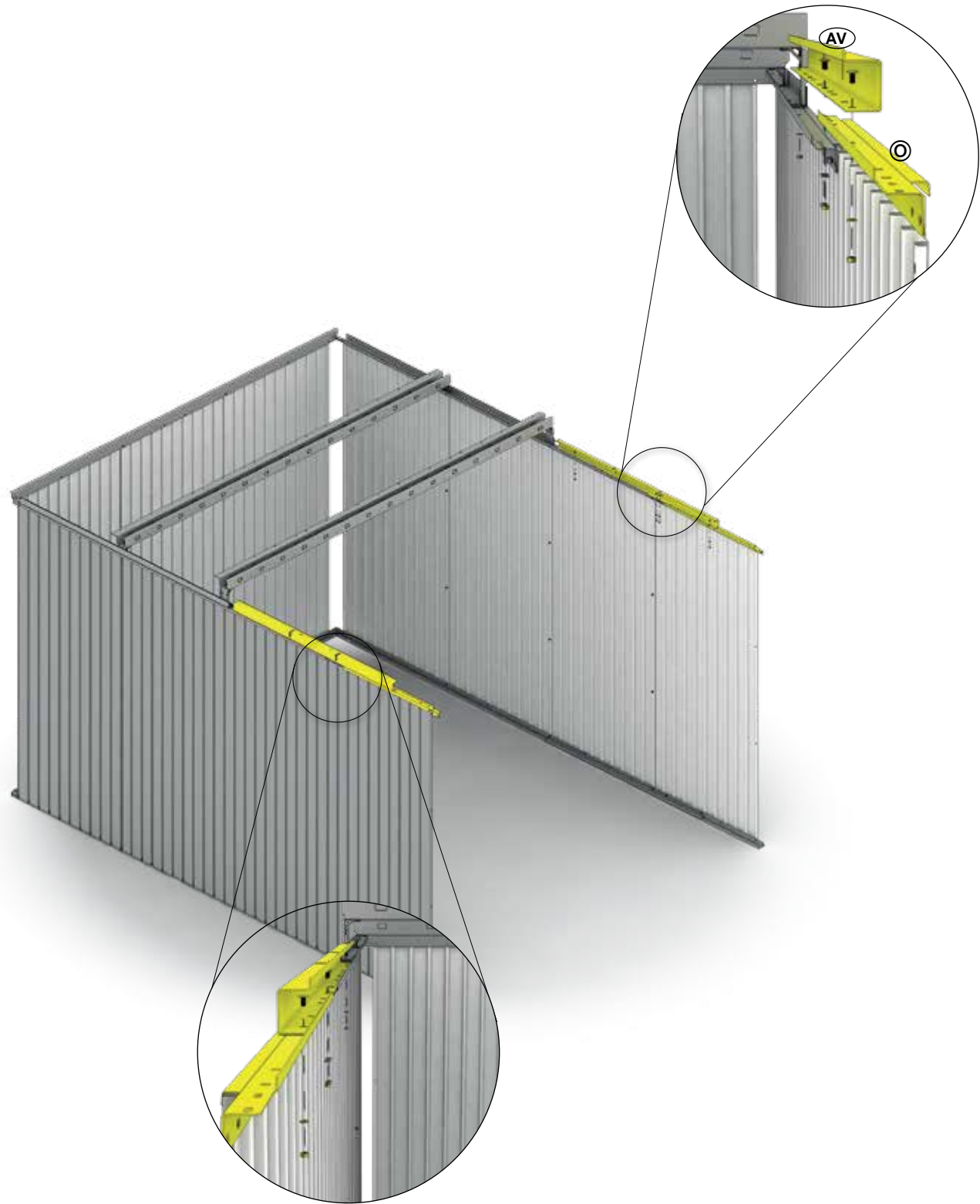

M5 x 10

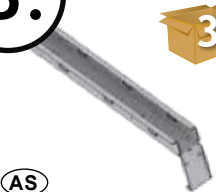

8x



8.

 AS	 1x (2530mm)	 AN	 2x	M5 x 10  D2	10x
 U	 1x				

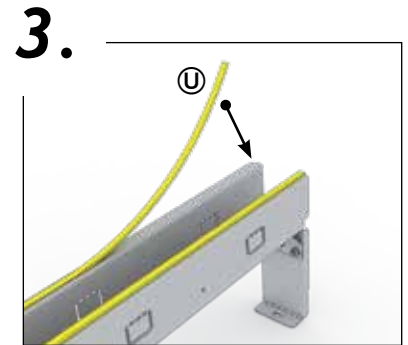
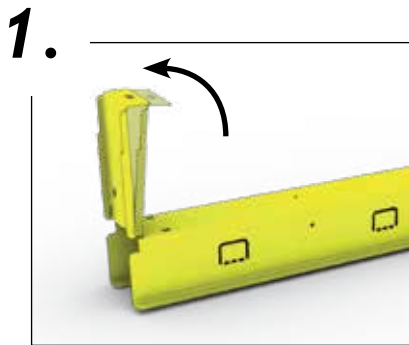

4.

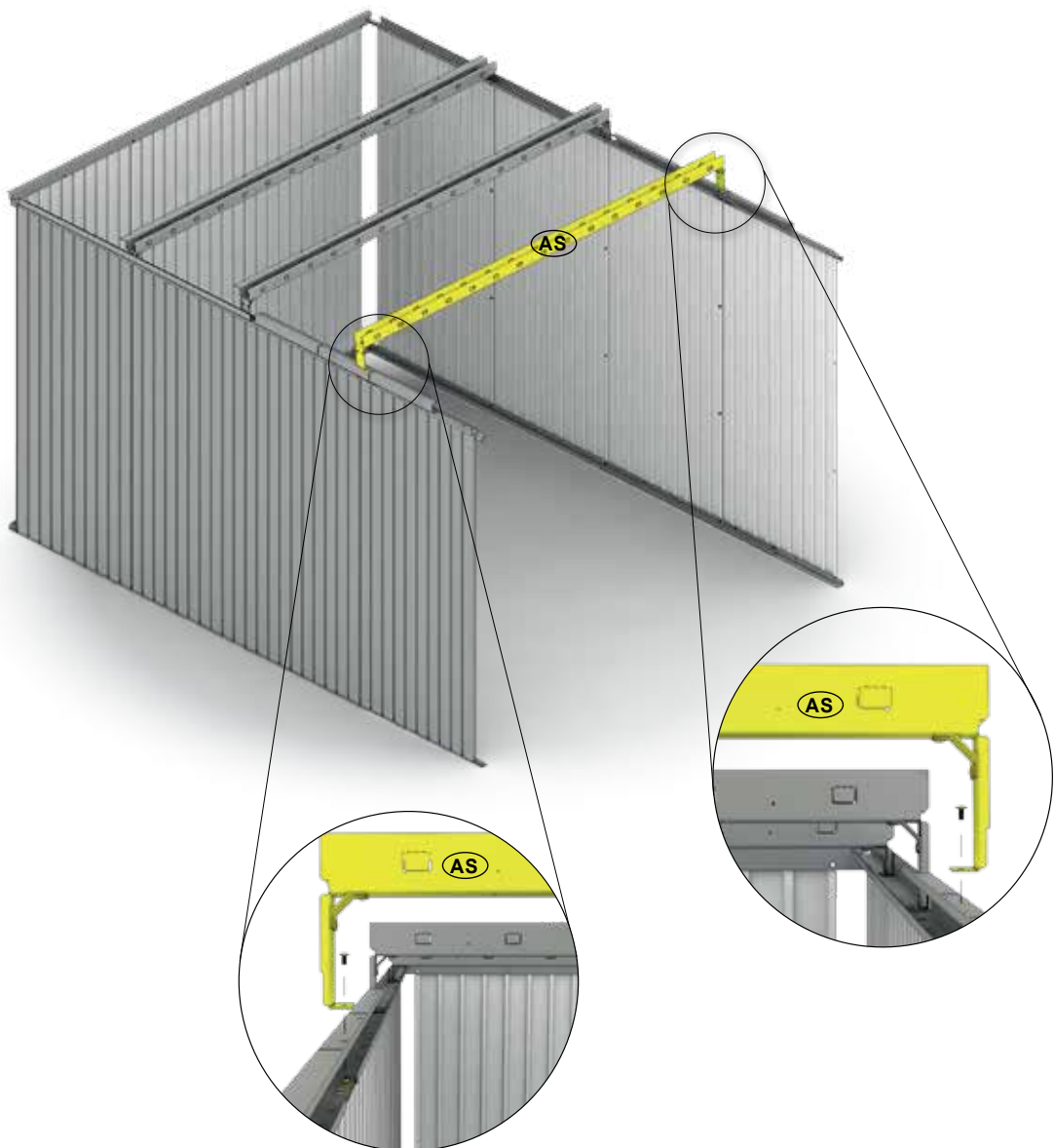



9.

M5 x 10



6x

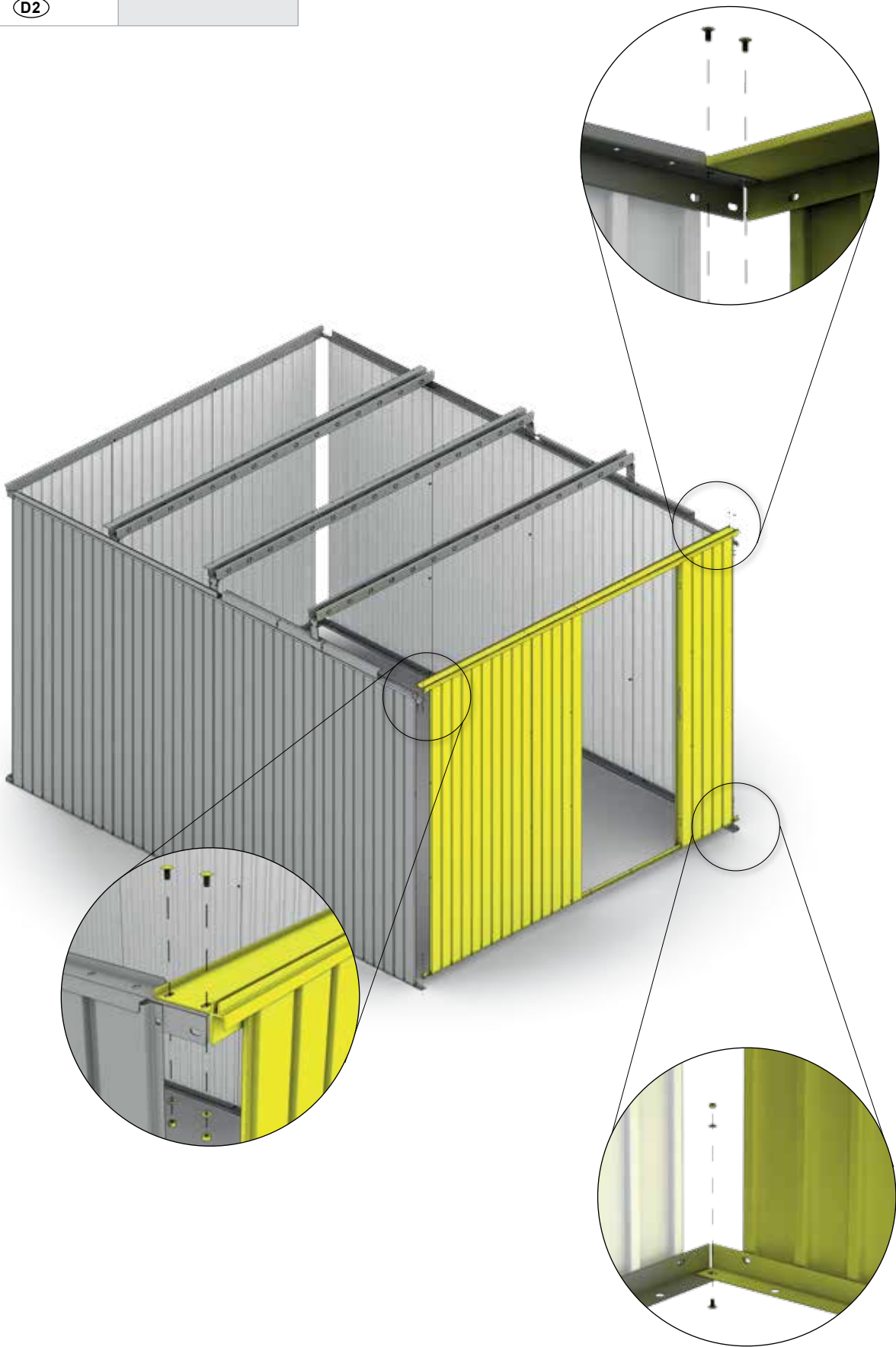

**10.**

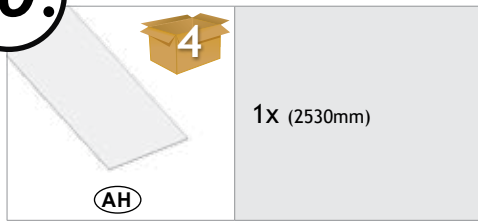

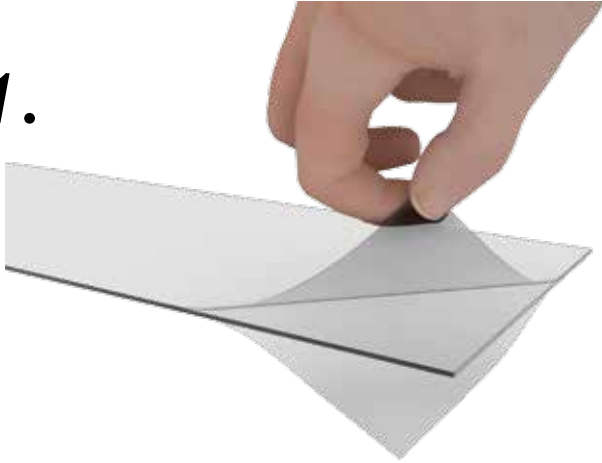

**1.**

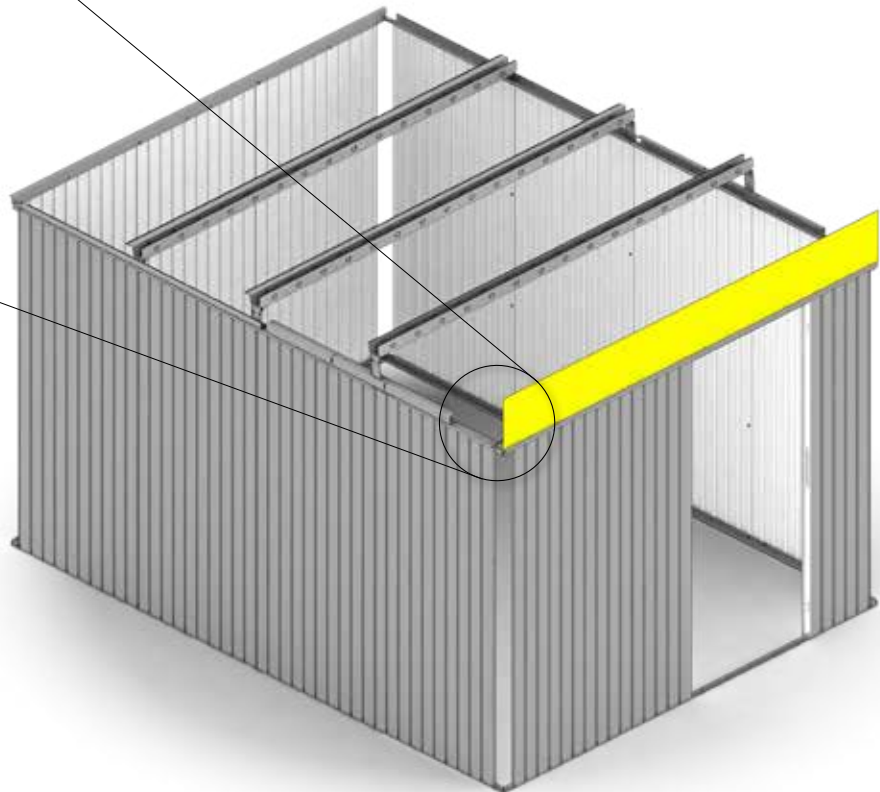
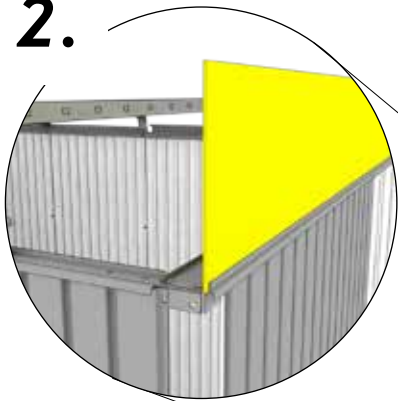

**2.**

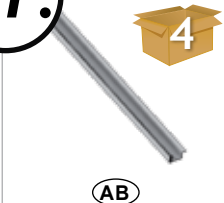

11.

 AB	1x (2530mm)	 U	1x
--	-------------	--	----

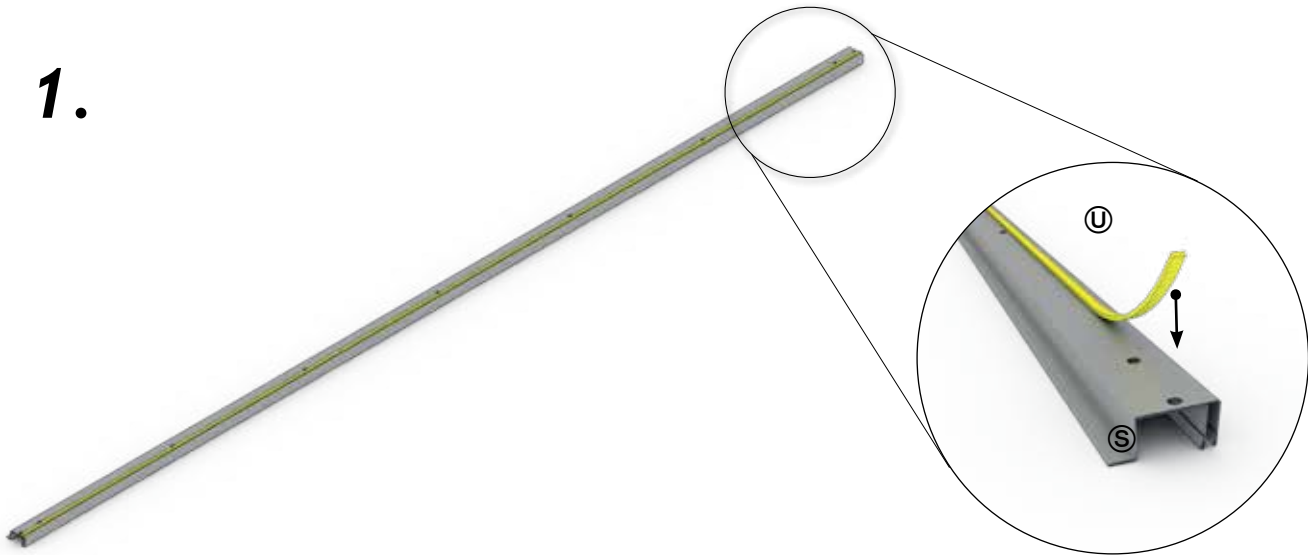

1.

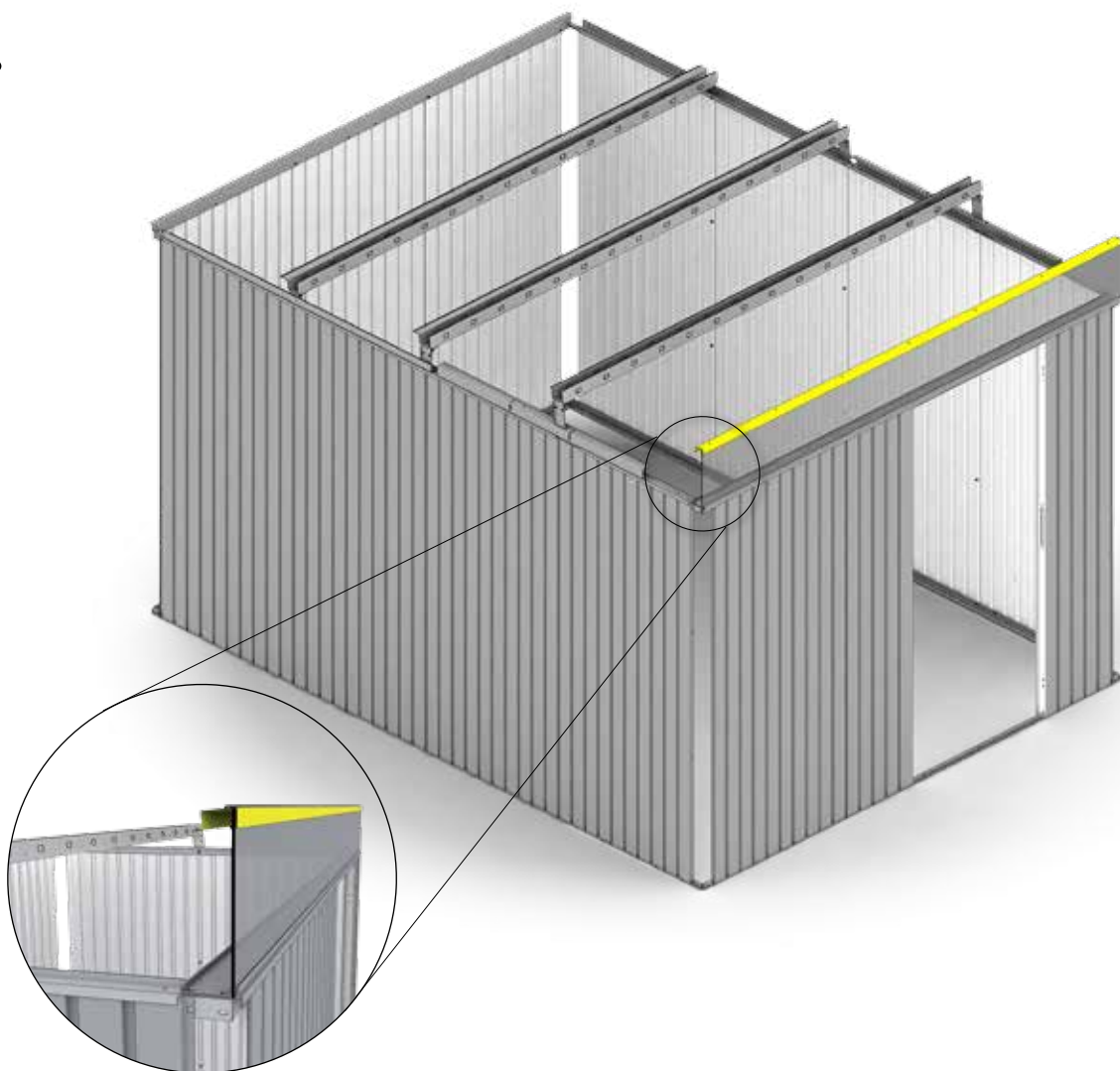

2.



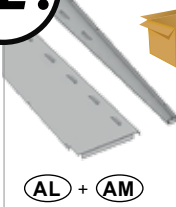
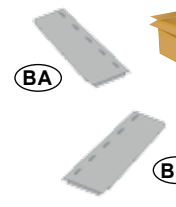

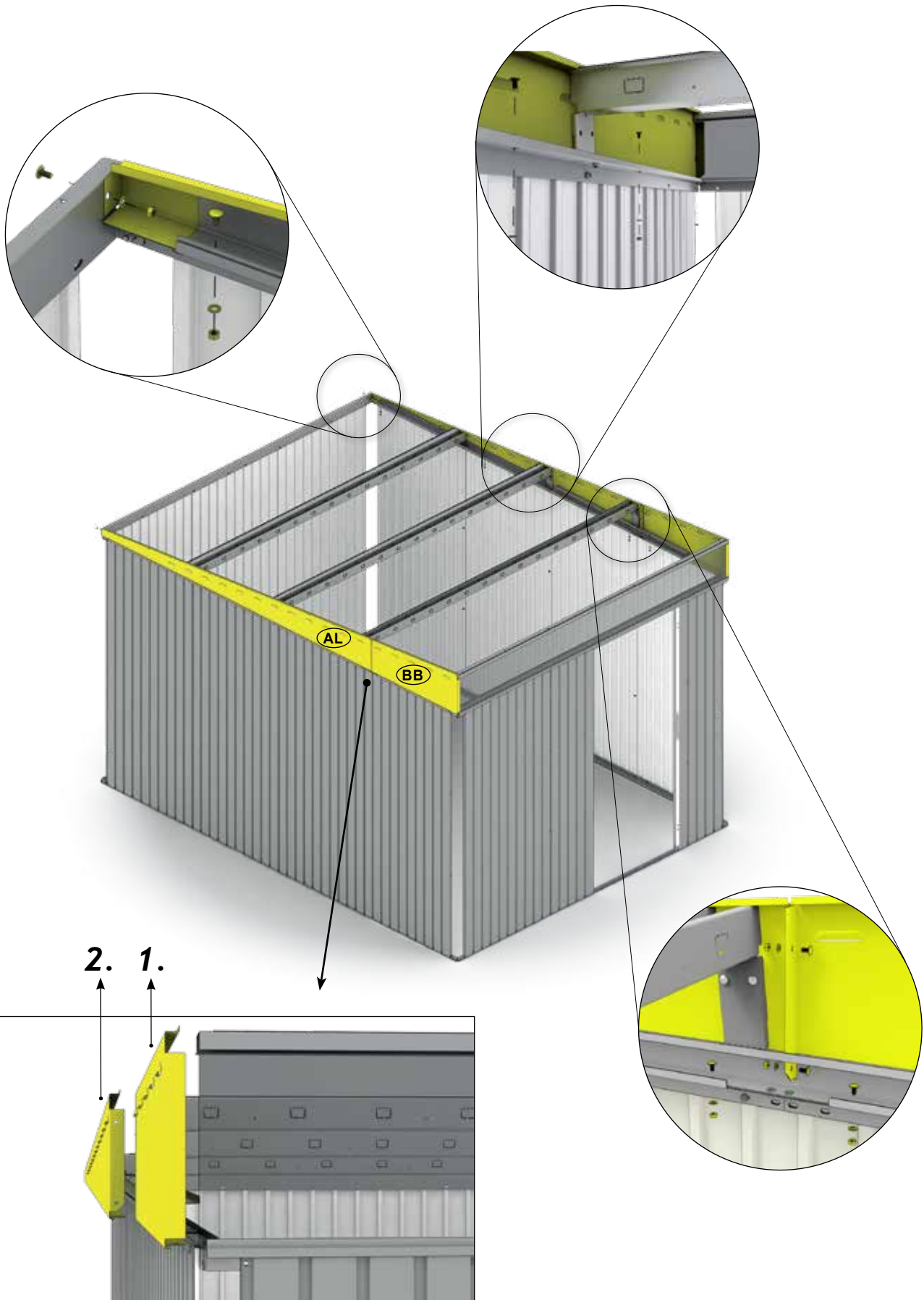

12.

 4 (AL) + (AM)	2x (2520mm)	 5 (BA) (BB)	2x (800mm)	M5 x 10  (D2)	16x
--	-------------	---	------------	--	-----



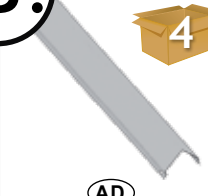

13.

 AD	4 2x	 AC	4 2x	M5 x 10  D2	32x
 D1	2x				

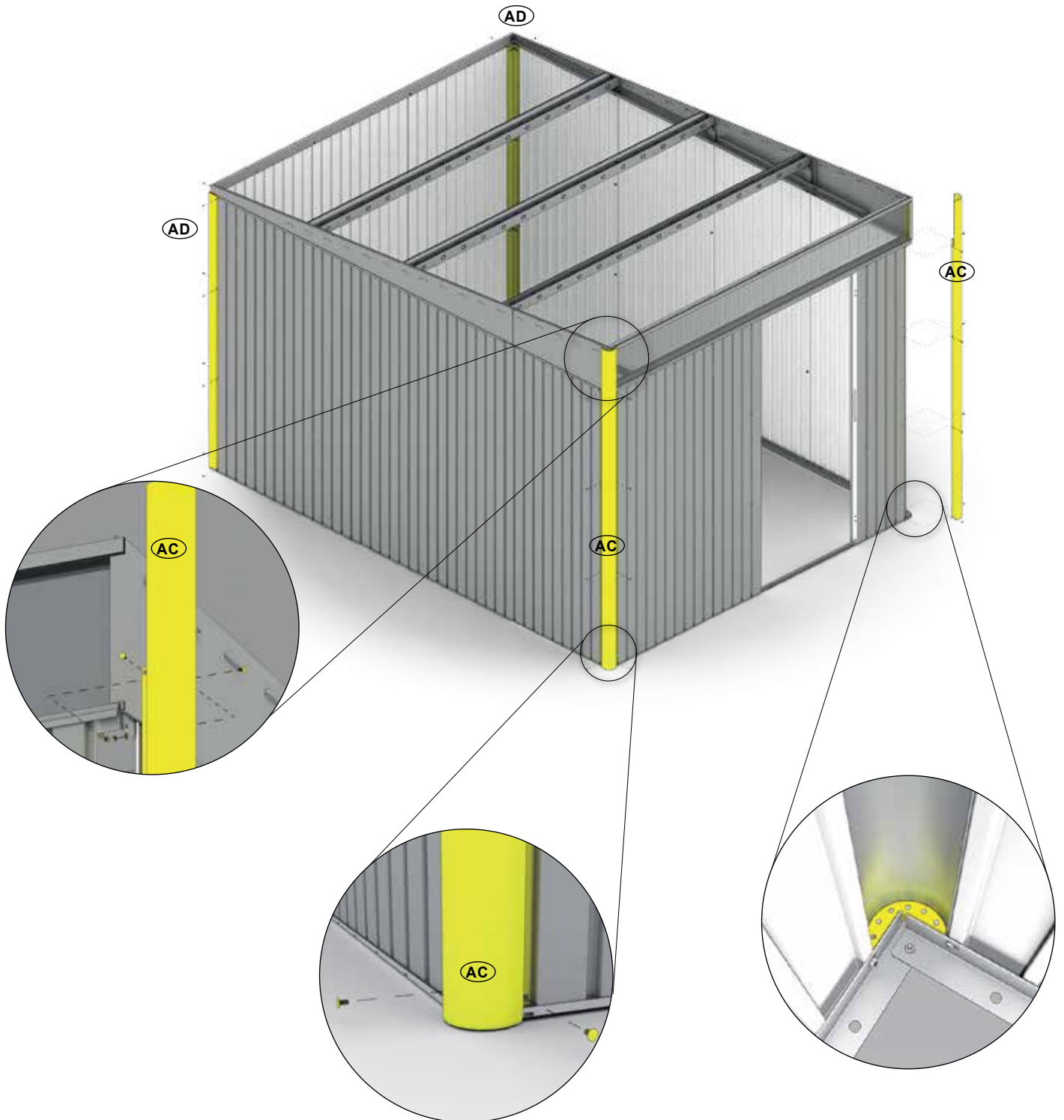



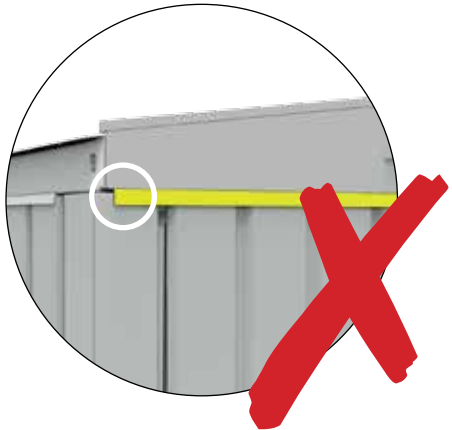
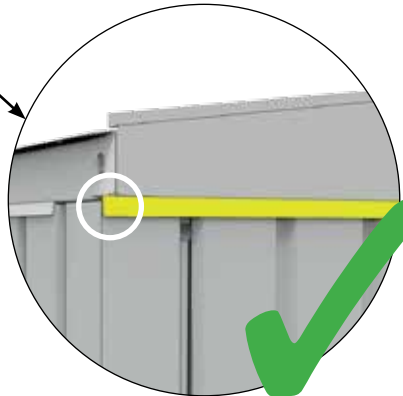
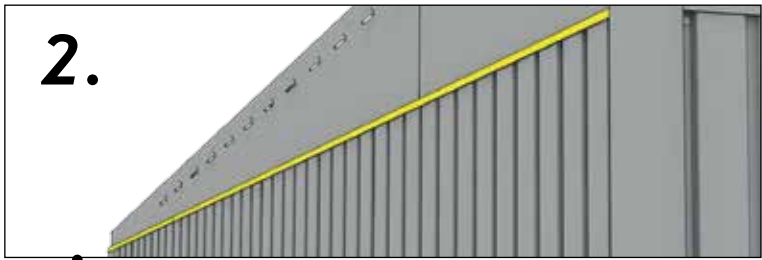
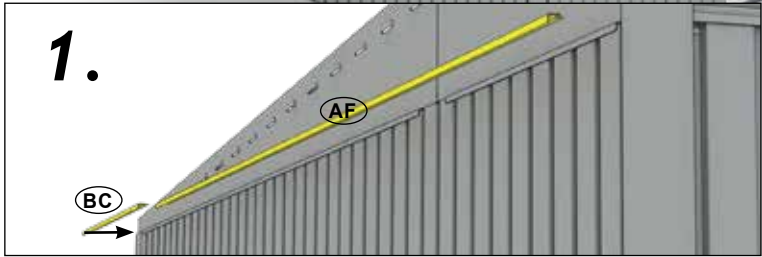
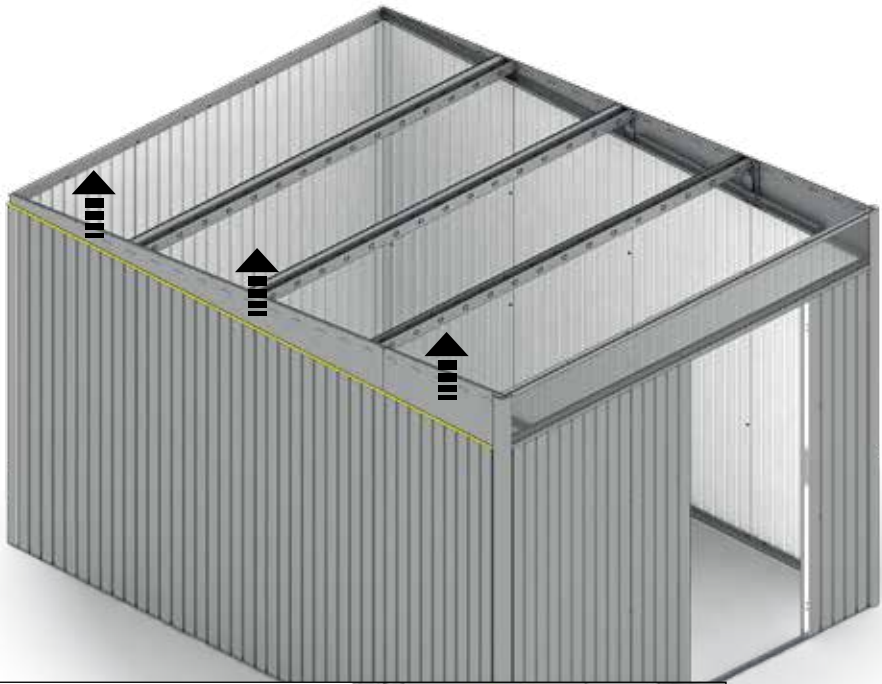
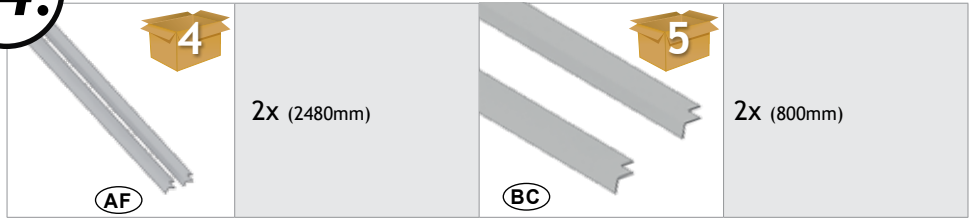



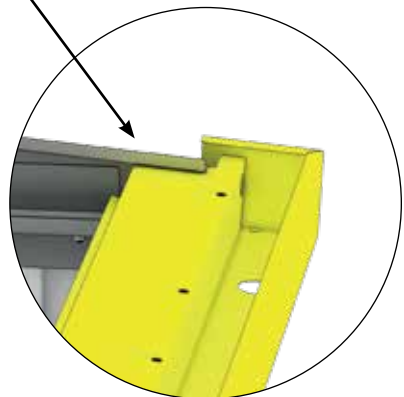
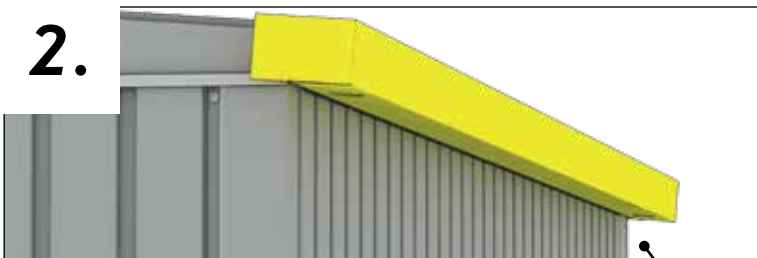
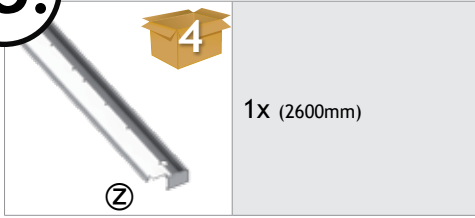

14.



**15.**

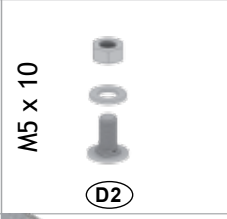

**16.**

 <b>4</b> 1x (2150mm)	 <b>4</b> 4x (2150mm)	 <b>4</b> 1x (2150mm)
 <b>4</b> 2x	 <b>D2</b> 54x	 <b>D2</b> 2x
 <b>5</b> 1x (1760mm)	 <b>5</b> 4x (1760mm)	 <b>5</b> 1x (1760mm)

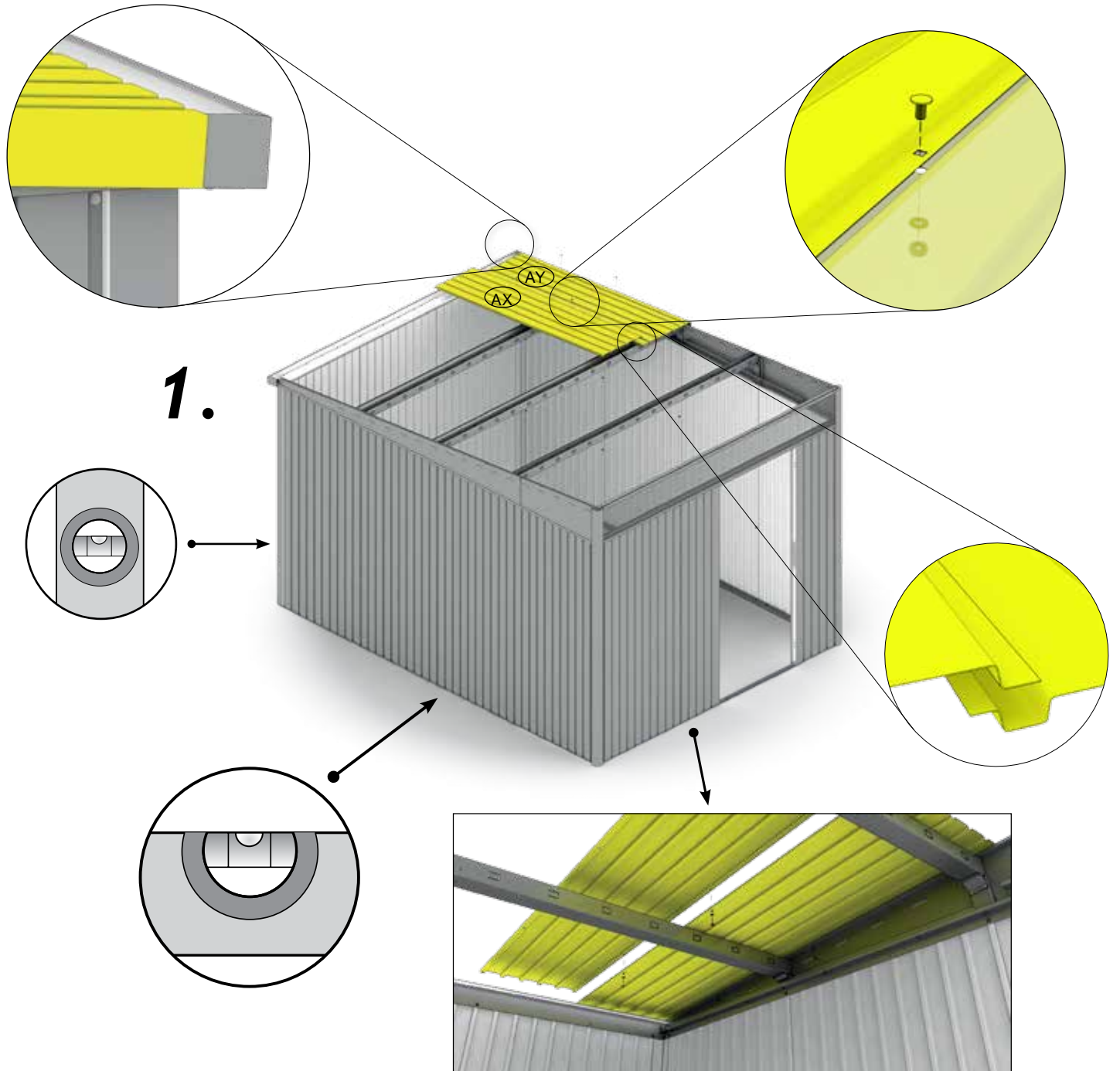



## Rechtwinkelig einrichten

- ⒸB rectangular adjusted
- ⒻR ajuster en forme rectangulaire
- ⒸNL rechthoekig instellen
- ⒸES ajustar en forma rectangular
- ⒸIT Mettere in squadra

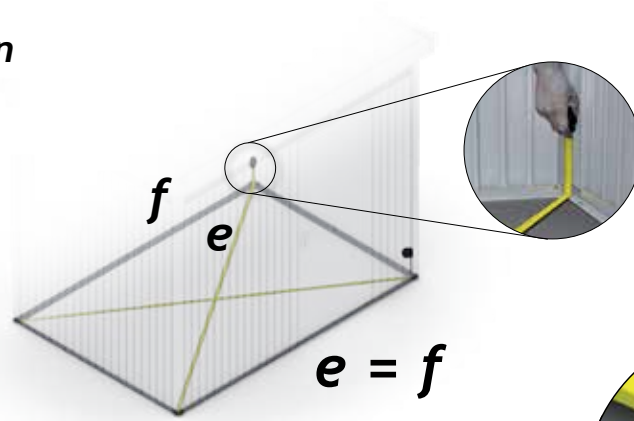

2.

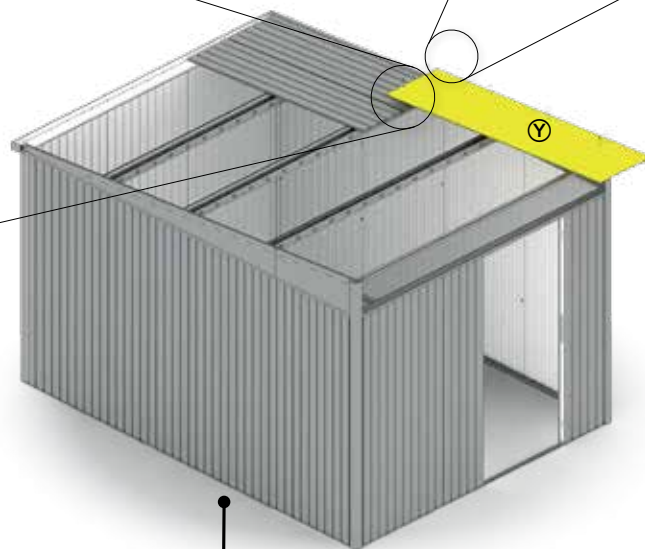
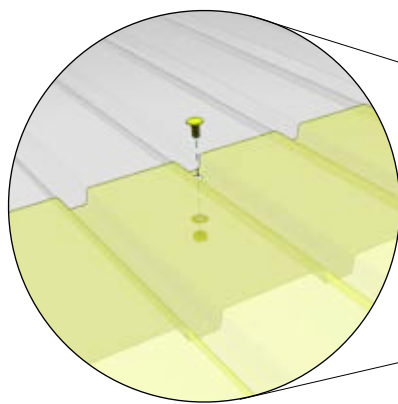

4,8x13

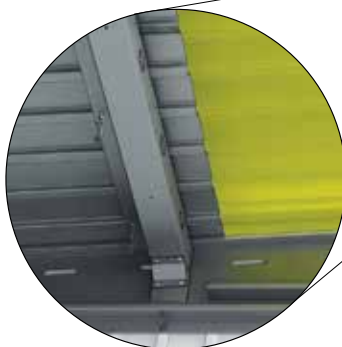

3.

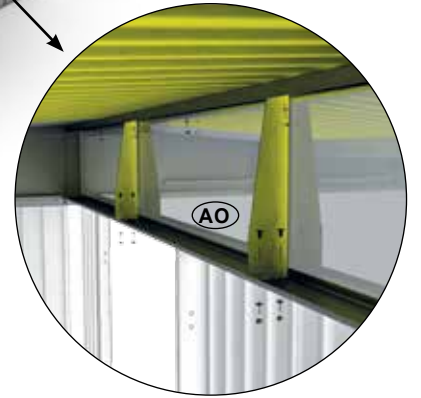
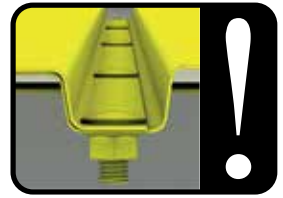
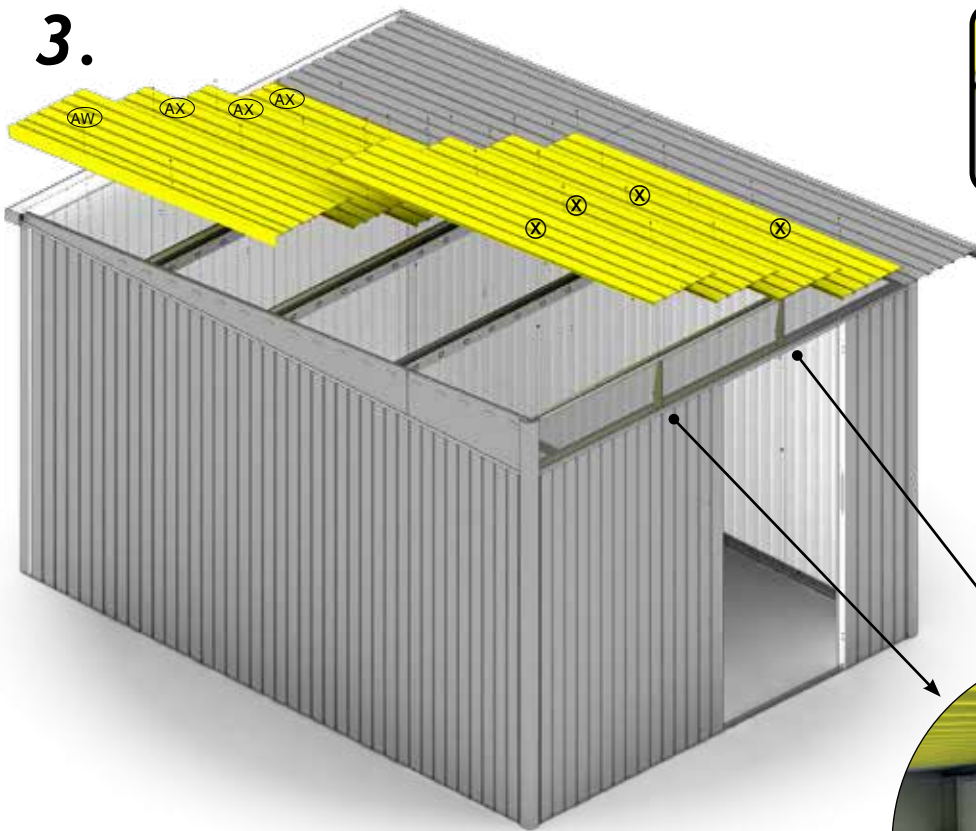

4.



4,8x13

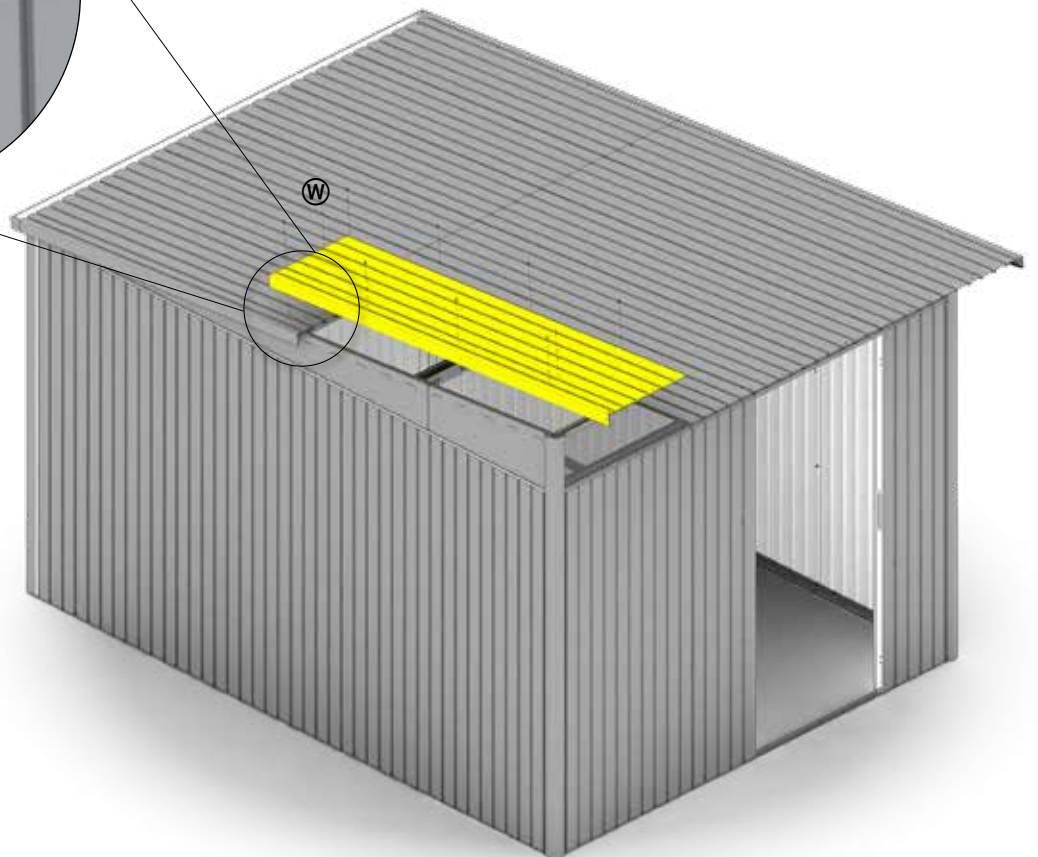

17.

4,8 x 13



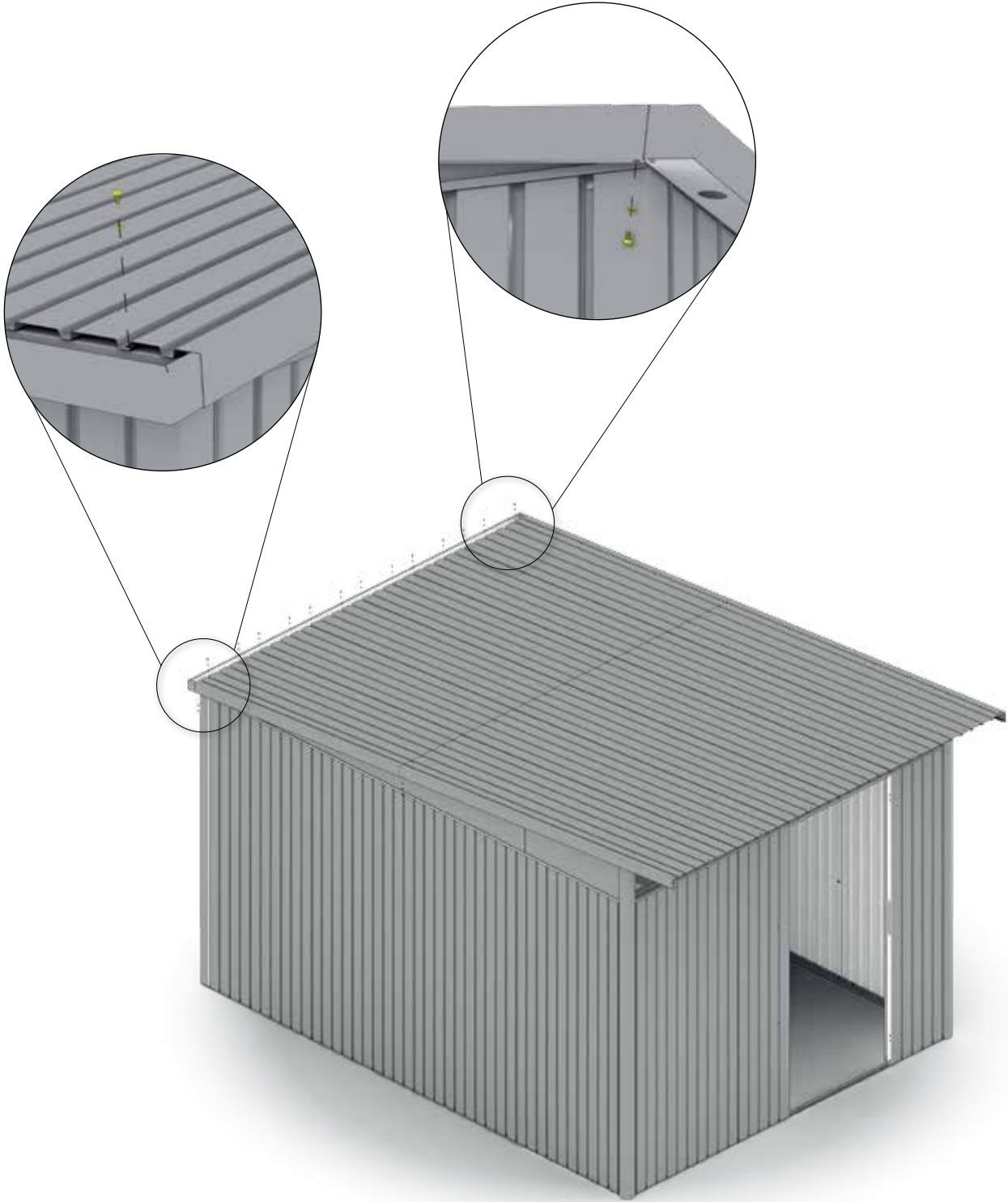

D2

15x



18.

 AA	 1x (2600mm)	M5 x 10  D2	10x
--	--	--	-----

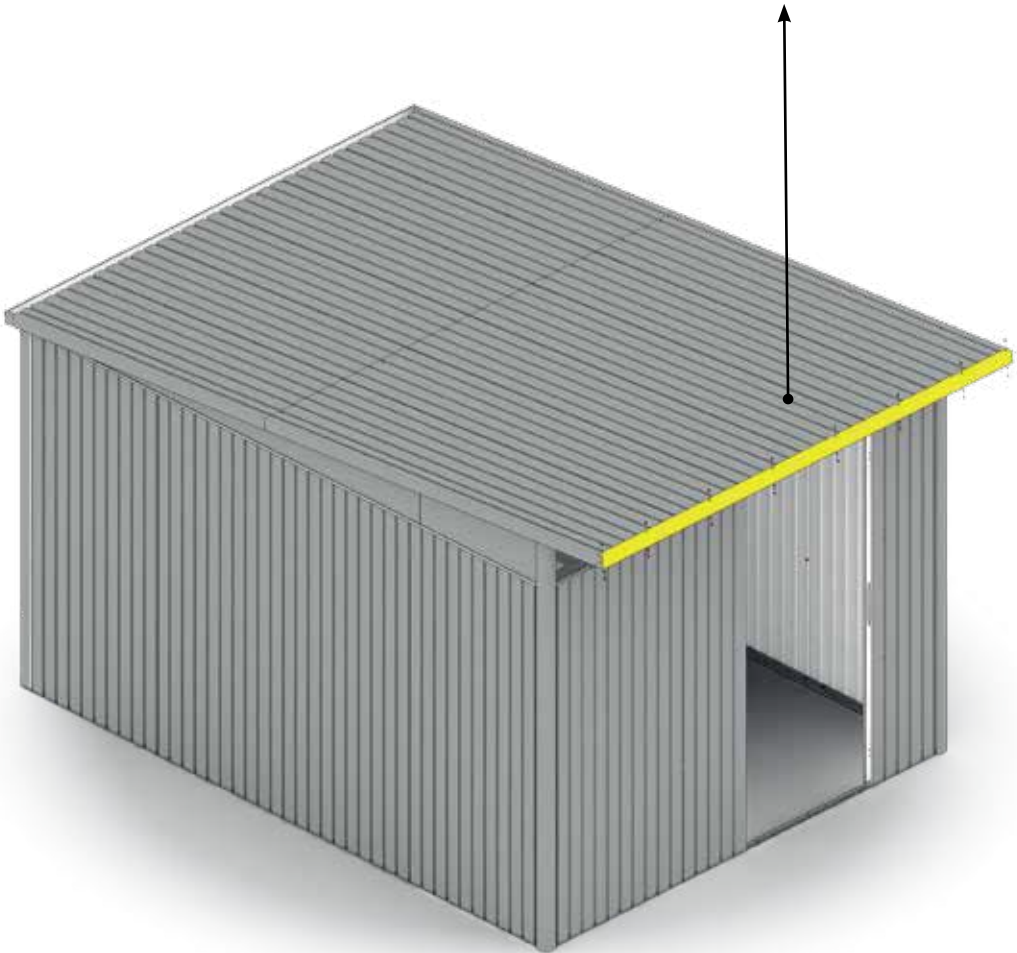
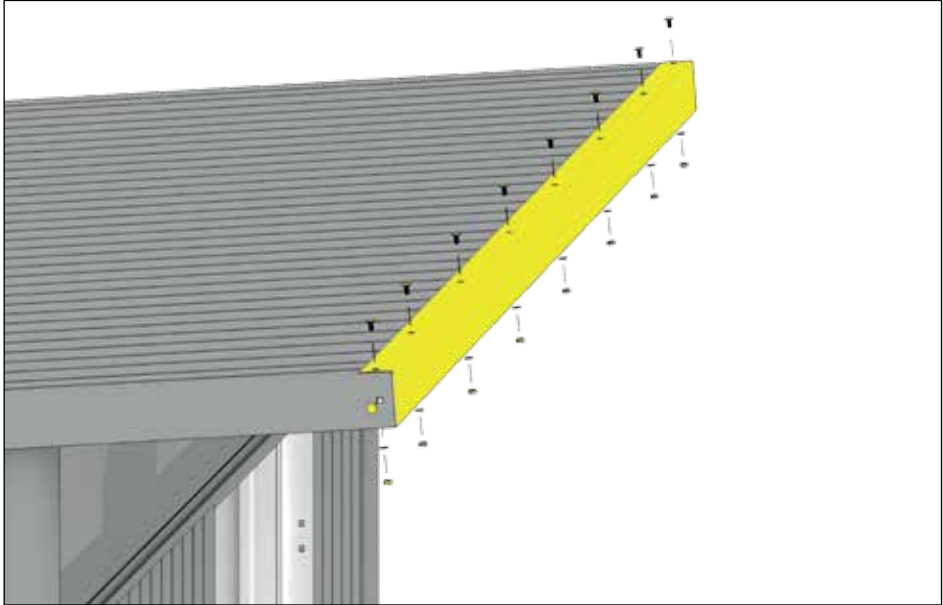



19.

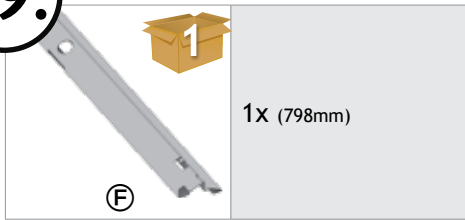

**Bei Verwendung der Bodenschwellen-Rampe überspringen Sie diesen Schritt!**

- Ⓒ GB If you use the floor ramp (optional accessory), please skip this step!
- Ⓒ FR Si vous utilisez le seuil de porte (accessoire) veuillez passer les étape!
- Ⓒ NL Bij toepassing van de oprijplaat (toebehoren) overslaan stap!
- Ⓒ ES Si utiliza rampa de acceso (accesorio opcional) omite este paso en el montaje
- Ⓒ IT Se usi la rampa di accesso (accessorio opzionale), puoi saltare questo passaggio

**Doppeltür**  
 (Double Door - Deuxième battant de porte - Tweede deurvleugel - Secondo battente - puerta doble)

1X (1596mm)

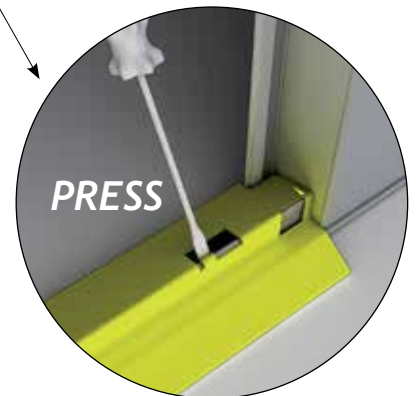
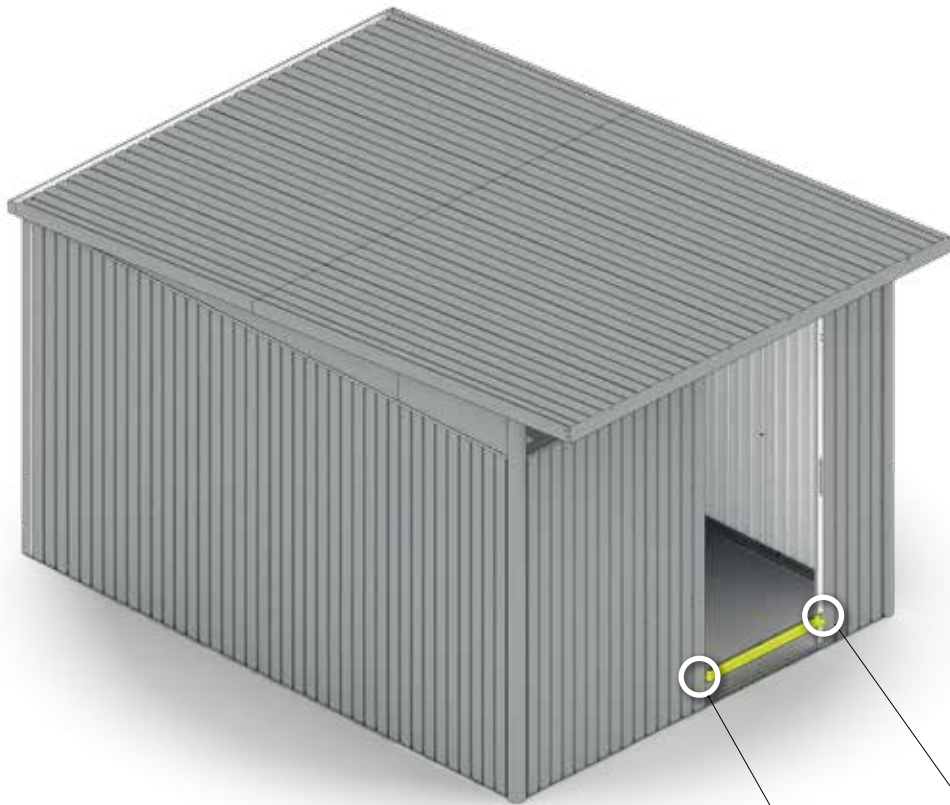



## Bodenrahmen

(Floor Frame - Cadre de sol - Telaio perimetrale - Bodemframe - marco de suelo)

	1x	6,3 x 22		1x
--	----	----------	--	----

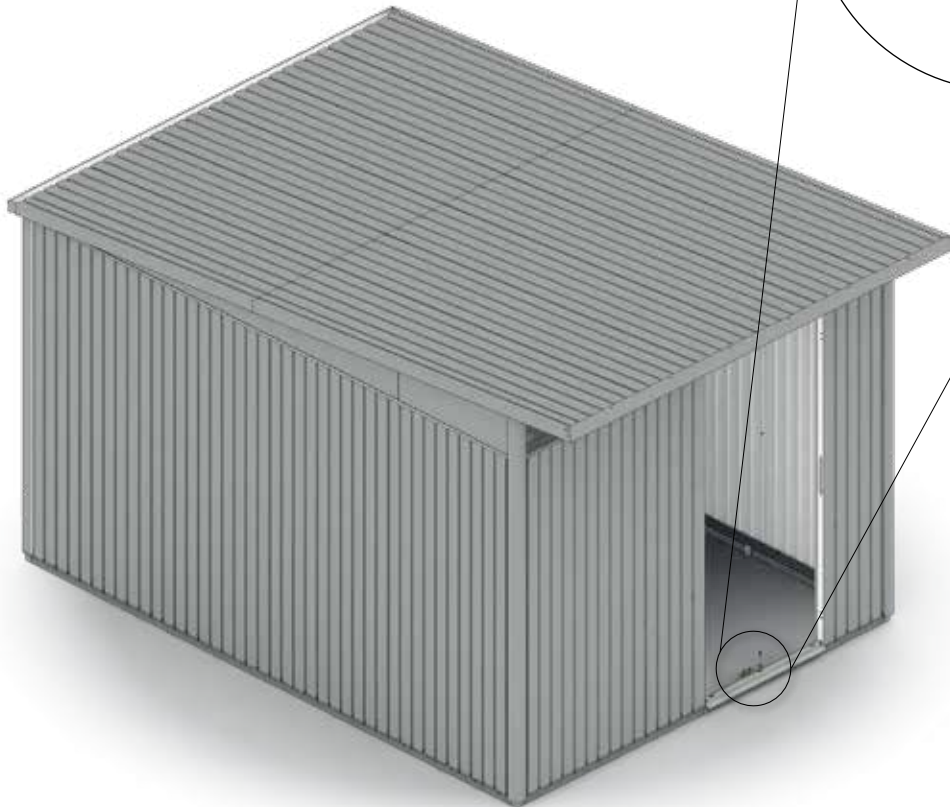
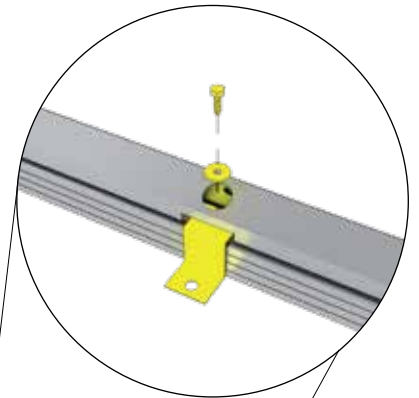

## Doppeltür

(Double Door - Deuxième battant de porte - Tweede deurvleugel - Secondo battente - puerta doble)

	2x	6,3 x 22		2x
--	----	----------	--	----

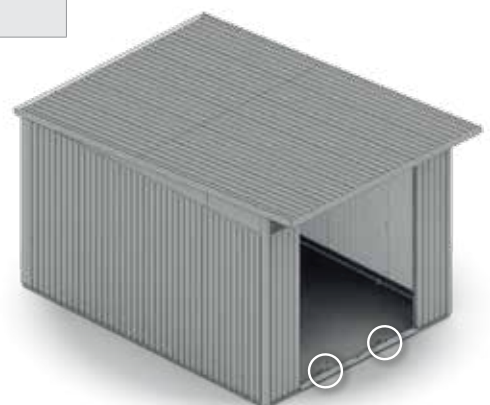



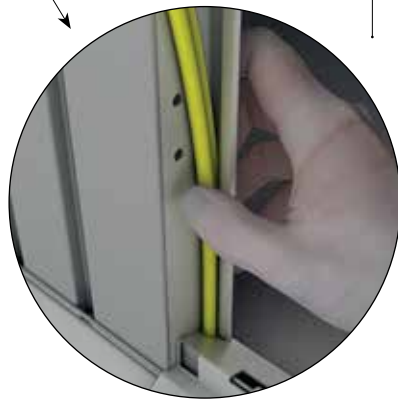
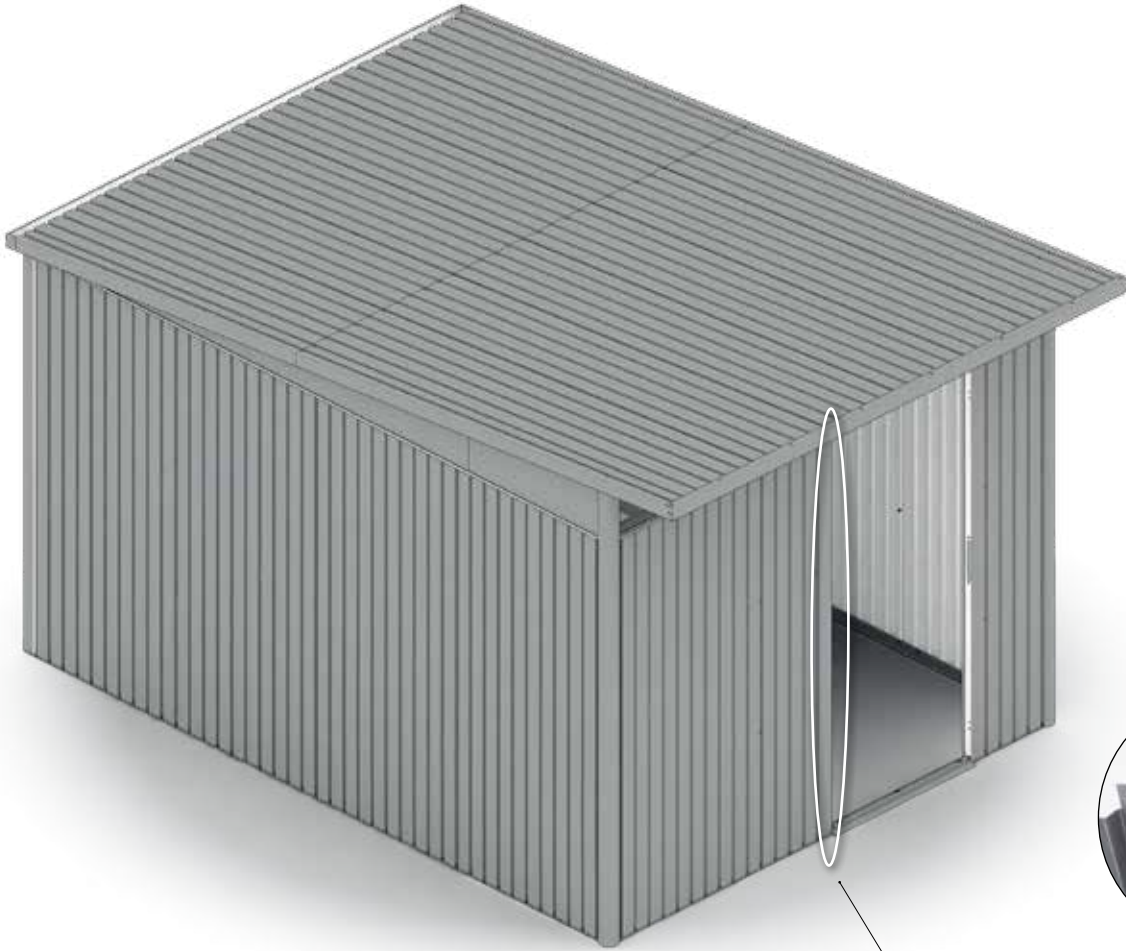
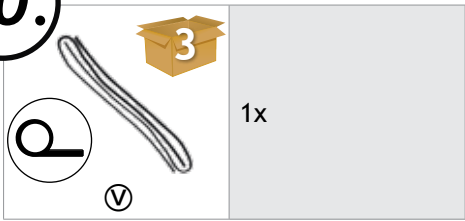



20.





## Doppeltür



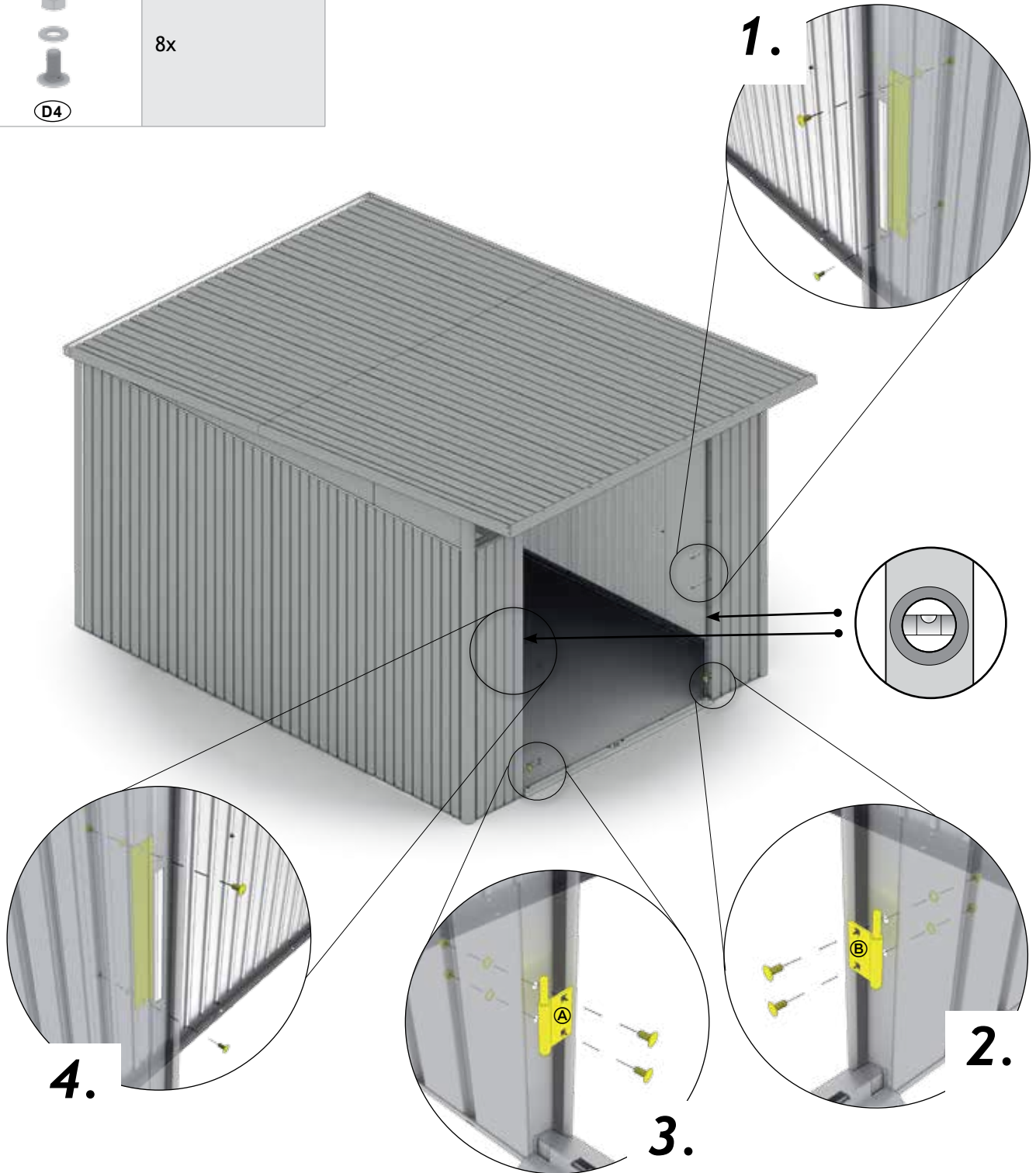

(Double Door - Deuxième battant de porte - Tweede deurvleugel - Secondo battente - puerta doble)

 ①	 2x	 Ⓐ	 1x	 Ⓑ	 1x
M5 x 10  ⒹⒹ	8x				



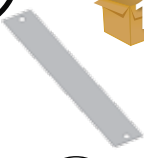

**21.**

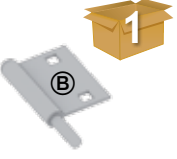
 ①	1x	 ①	1x	M5 x 12  ④	2x
M5 x 10  ④	8x	 ①	1x		

**1.**

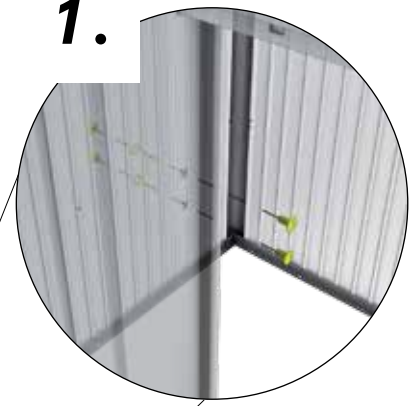

**2.**

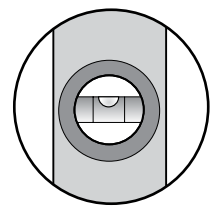
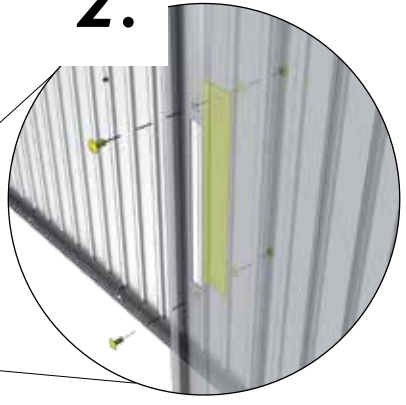

**3.**

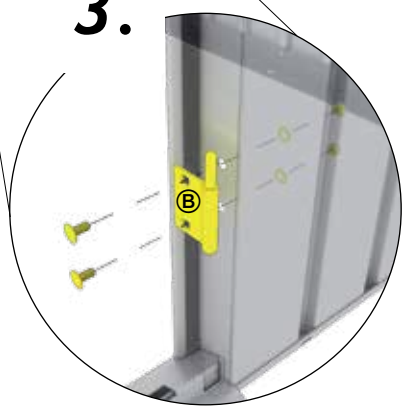

**4.**

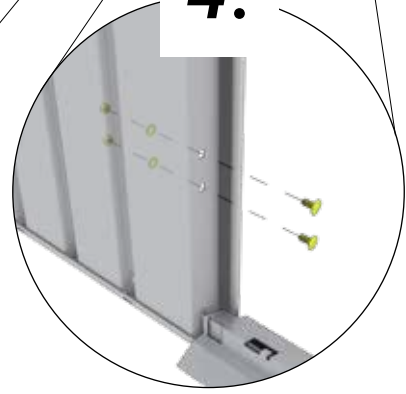

**5.**

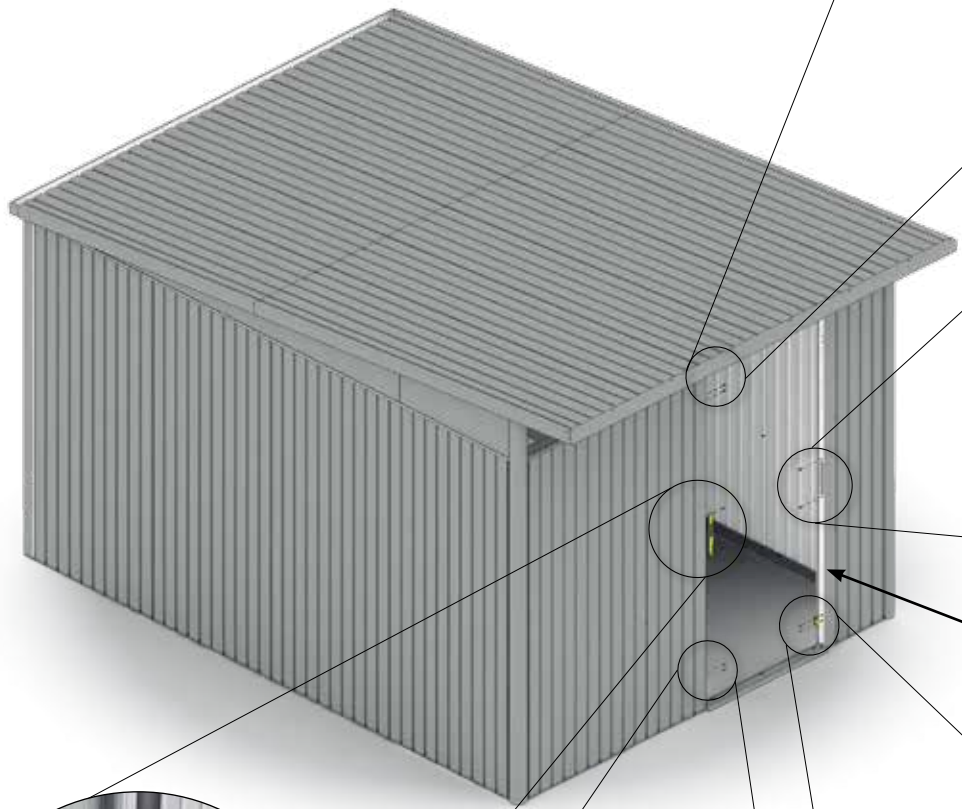
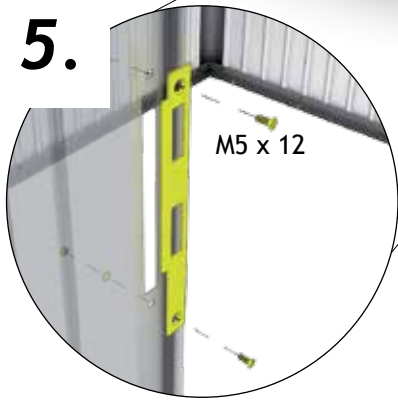





# Doppeltür

(Double Door - Deuxième battant de porte - Tweede deurvleugel - Secondo battente - puerta doble)

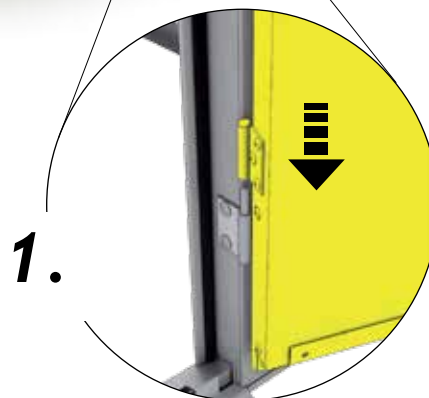
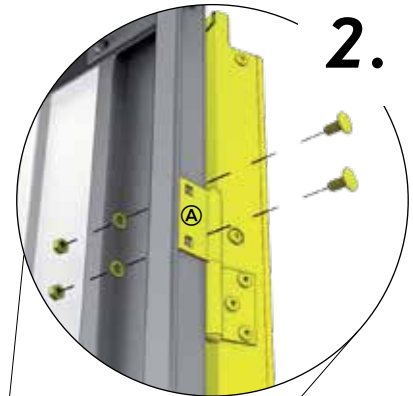
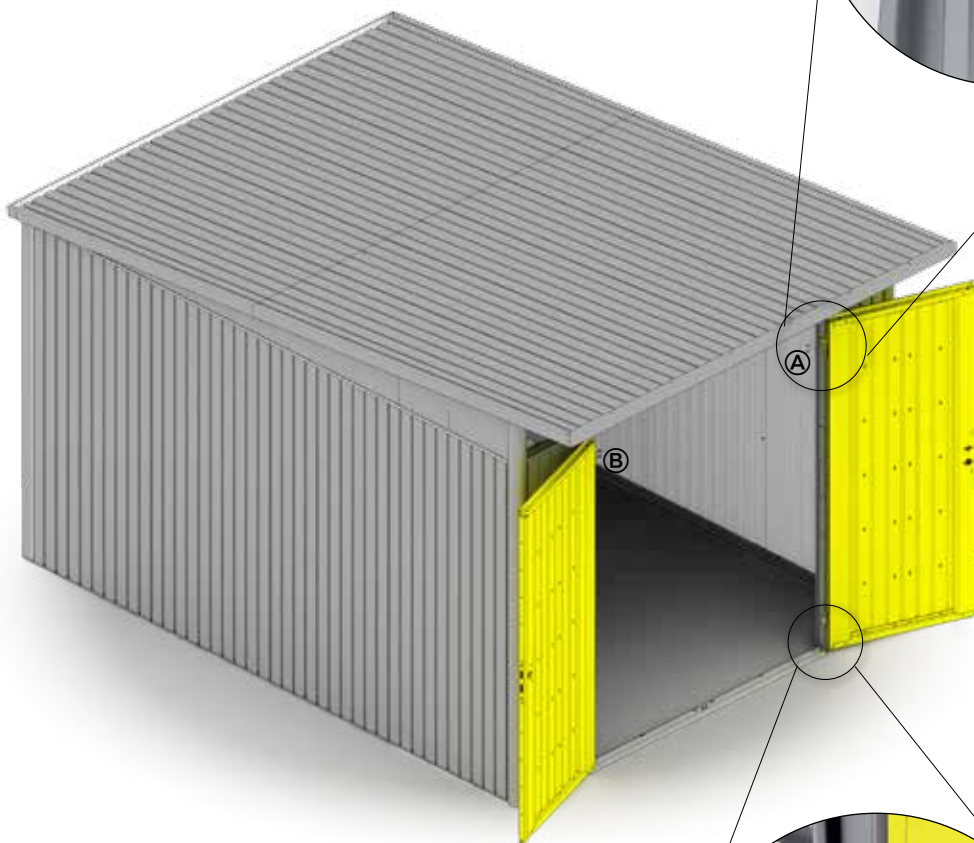
<p><b>B</b></p>	<p>1x</p>	<p><b>A</b></p> <p><b>D4</b></p>	<p>1x</p>	<p>M5 x 10</p> <p><b>D4</b></p>	<p>4x</p>
<p><b>ZA</b></p>	<p>1x</p>	<p><b>B</b></p> <p><b>D4</b></p>	<p>1x</p>		

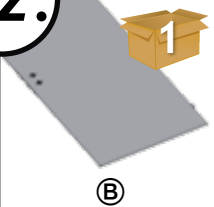
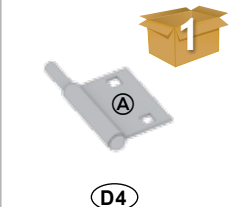

22.

 Ⓑ	1x	 Ⓐ	1x	M5 x 10  Ⓓ	2x
--	----	---	----	---	----

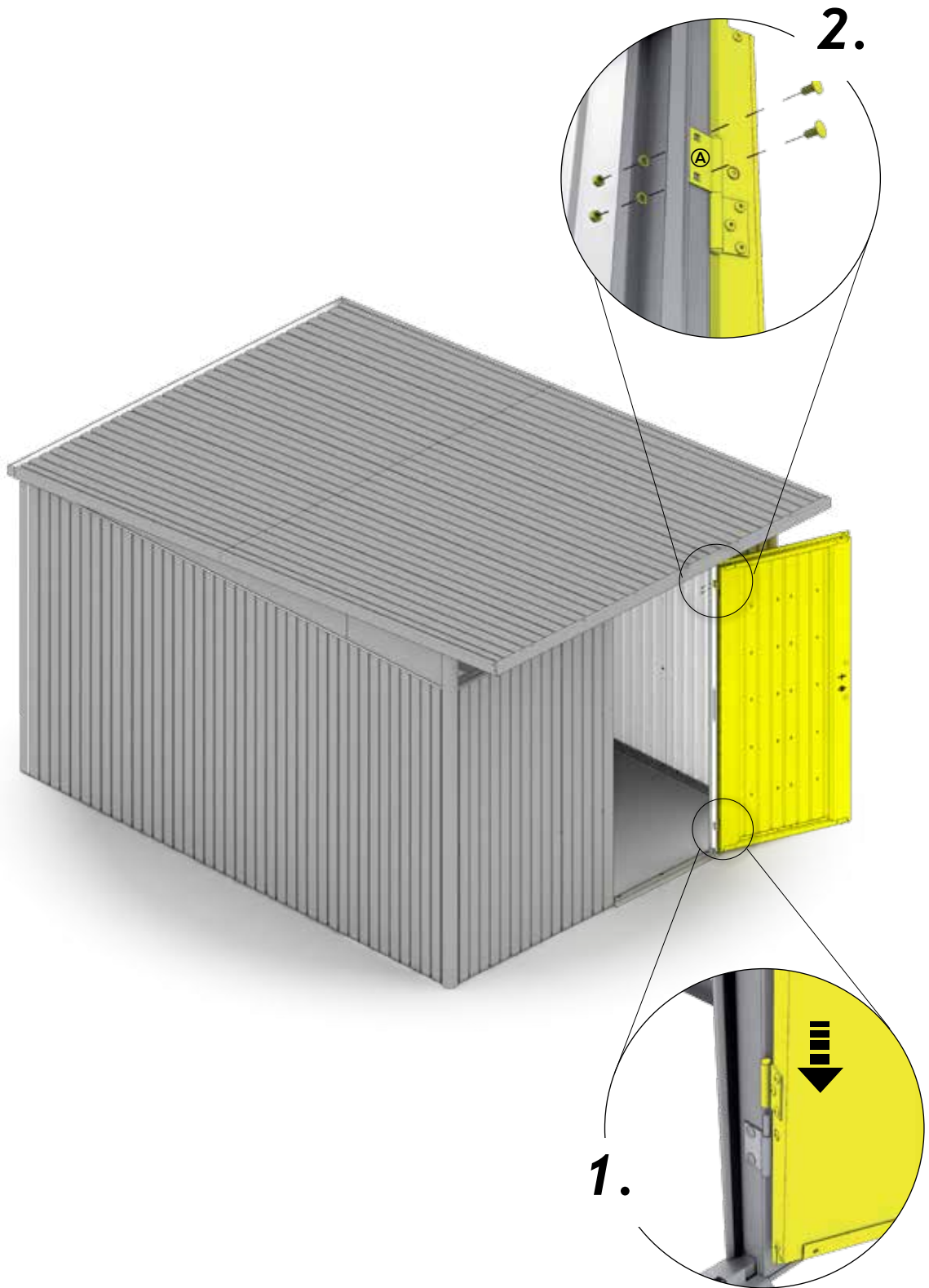

23.

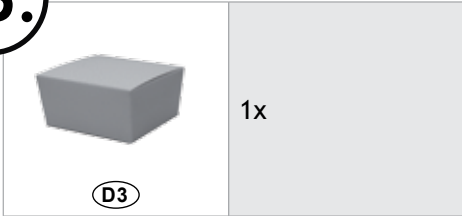

**Reserveschlüssel für Nachfertigung separat aufbewahren!**

- (GB) Please keep a spare key separately in case you need to make copy
- (FR) Veuillez conserver vos clés de réserve séparément.
- (NL) Reservesleutel a.u.b. apart bewaren. Dit i.v.m. eventuele nabestellingen!
- (ES) Guarde una llave de repuesto separadamente por si tiene que encargar una copia.
- (IT) Conservare la chiave di riserva in luogo sicuro per un' eventuale post-fabbricazione!



optionales Zubehör - Accessories - Accessoires - toebehoor - Accessori - Accesorios

**Doppeltür**

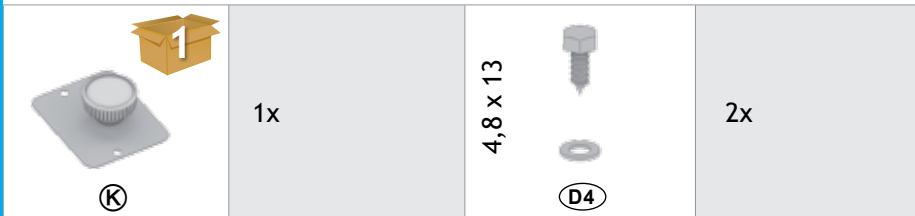

Double Door - Deuxième battant de porte - Tweede deurvleugel - Secondo battente - puerta doble





optionales Zubehör - Accessories - Accessoires - toebehoor - Accessori - Accesorios



24.

 J	1x	4,8 x 13  D2	5x	 D4	1x
--	----	---	----	---	----

**Doppeltür**  
(Double Door - Deuxième battant de porte - Tweede deurvleugel - Secondo battente - puerta doble)

 J	2x	4,8 x 13  D2	10x
 D4	2x		

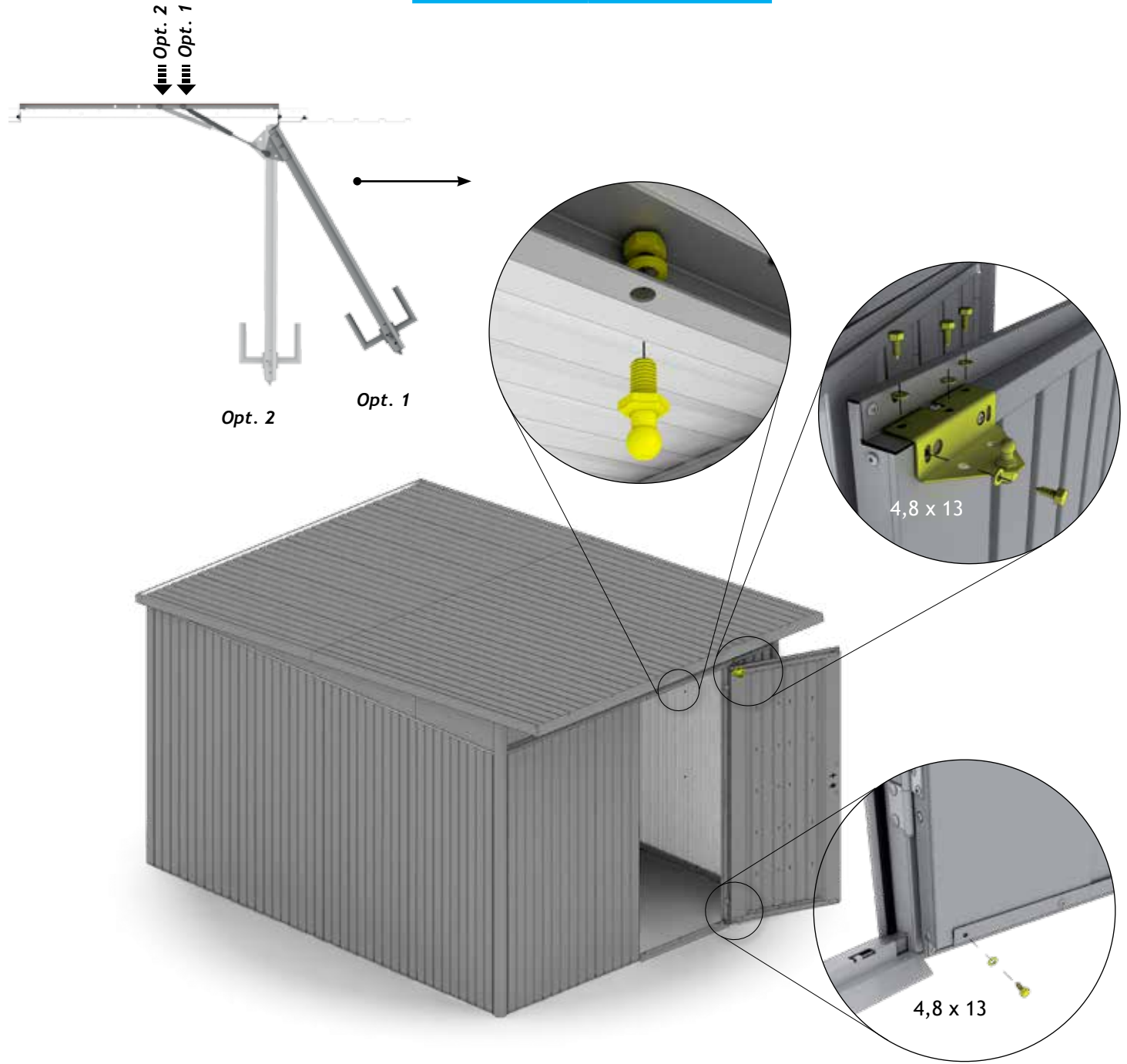

25.

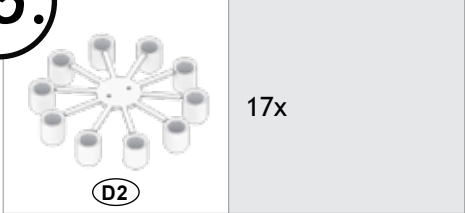

### Rechtwinkelig einrichten

- Ⓒ rectangular adjusted
- Ⓕ ajuster en forme rectangulaire
- Ⓓ rechthoekig instellen
- Ⓔ ajustar en forma rectangular
- Ⓗ Mettere in squadra

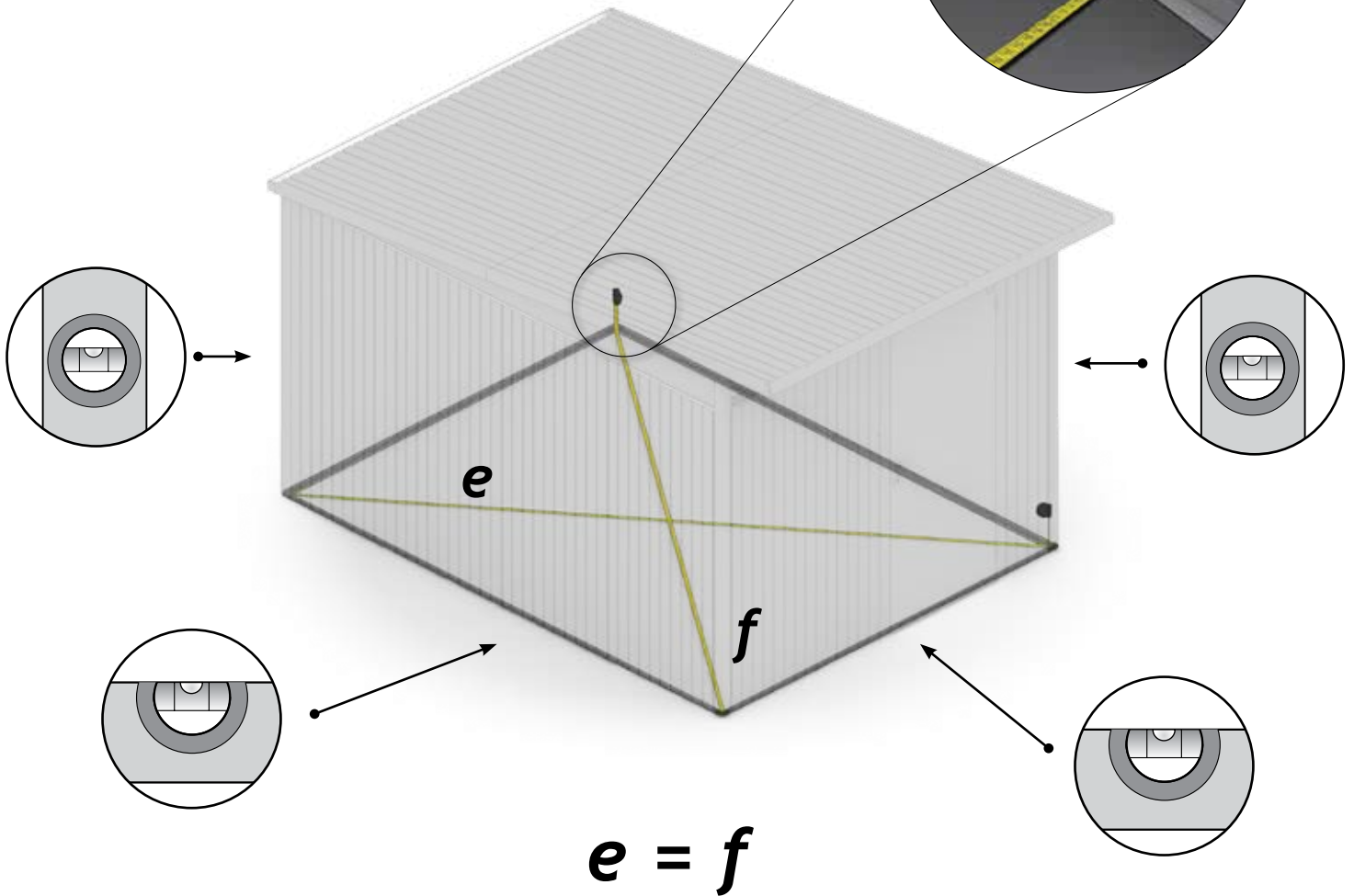

### Ziehen Sie jetzt alle Schraubenverbindungen fest an!

Tighten now all nuts and connections securely! - Serrez maintenant les vis à fond!  
 - Draai nu alle schroeven vast! - Ahora puede apretar y fijar todos los tornillos y tuercas - Adesso serrare a fondo tutti i dadi!



26.

## Tür einrichten

- Ⓒ align the door
- Ⓕ ajuster la porte
- Ⓖ deur afstellen
- Ⓔ ajuste la puerta
- Ⓜ messa a squadra della porta

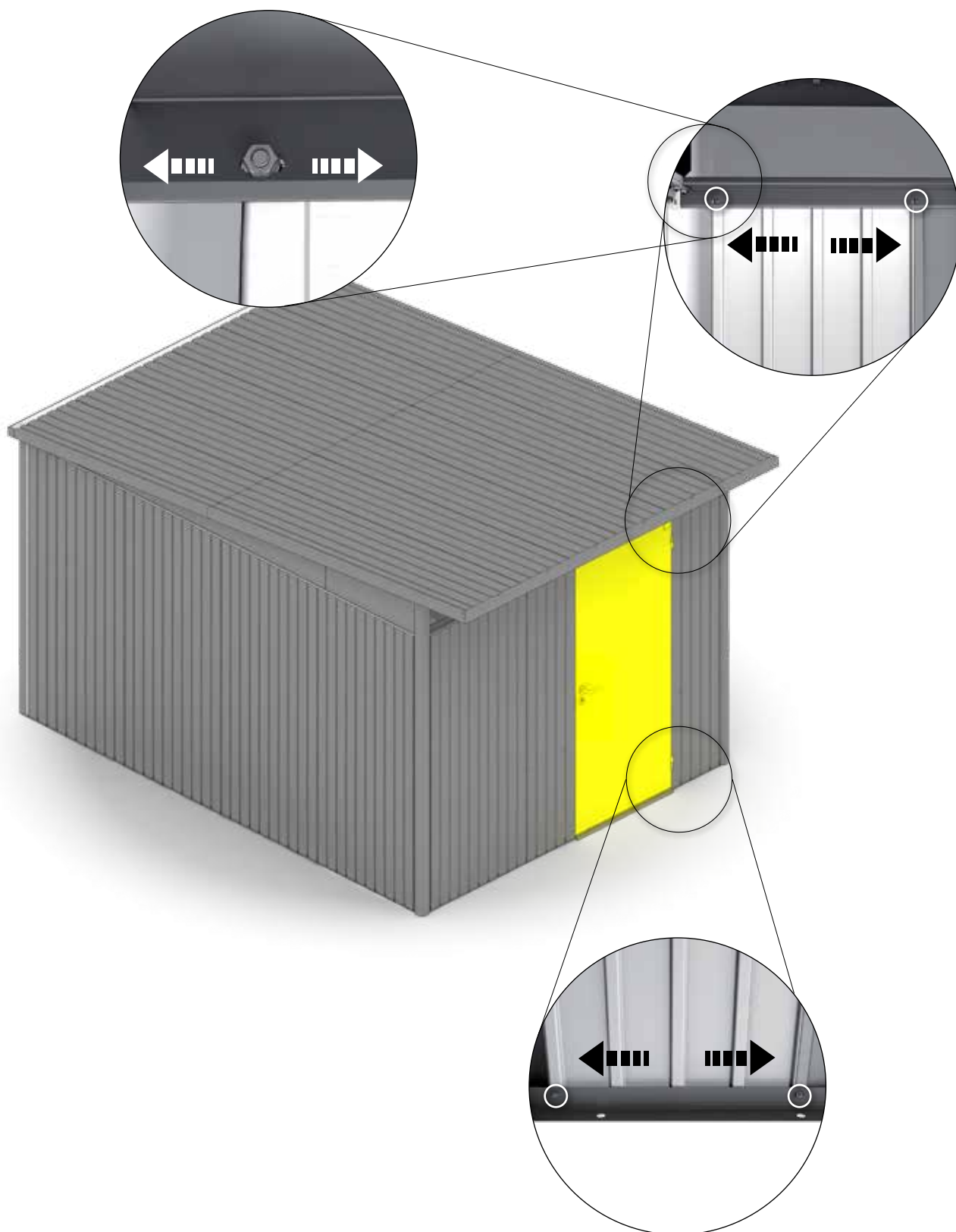

27.

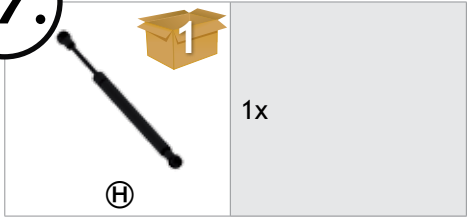

## Doppeltür

(Double Door - Deuxième battant de porte -  
Tweede deurvleugel - Secondo battente -  
puerta doble)

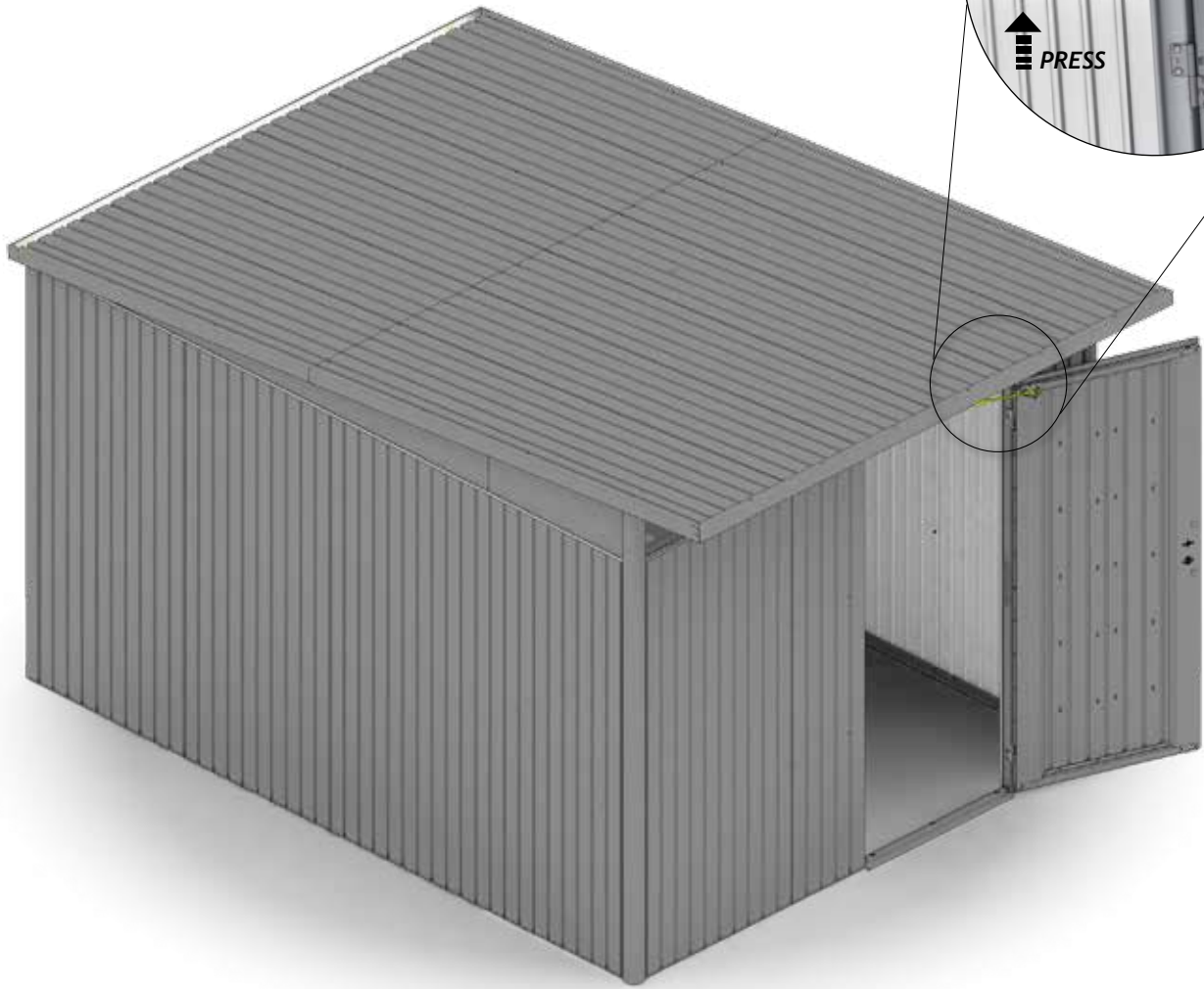
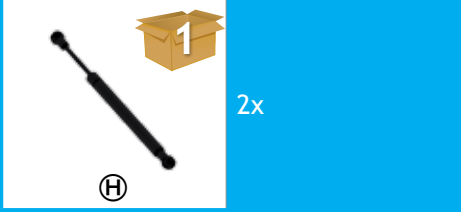





# Bodenrahmen

(Floor Frame - Cadre de sol - Telaio perimetrale - Bodemframe - marco de suelo)

## Variante 1, Proposal 1, Variant 1

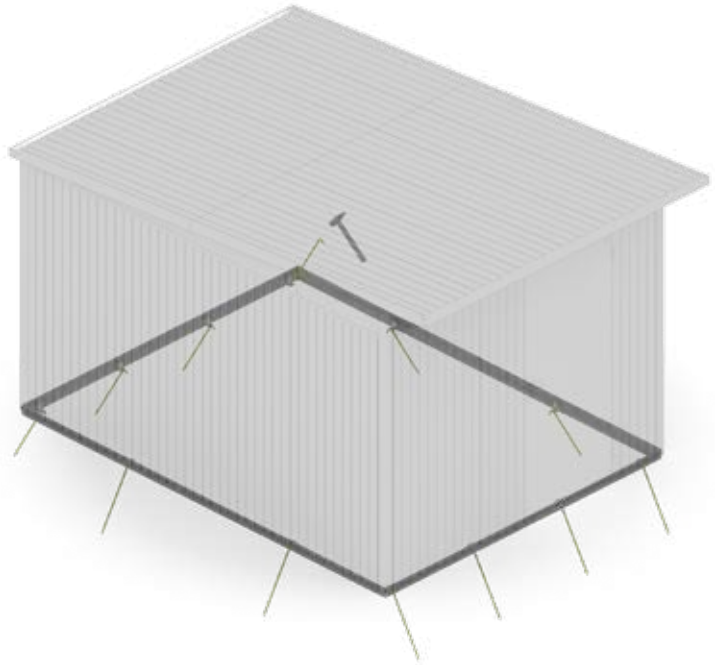
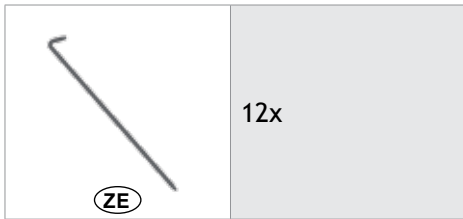

## Variante 2, Proposal 2, Variant 2

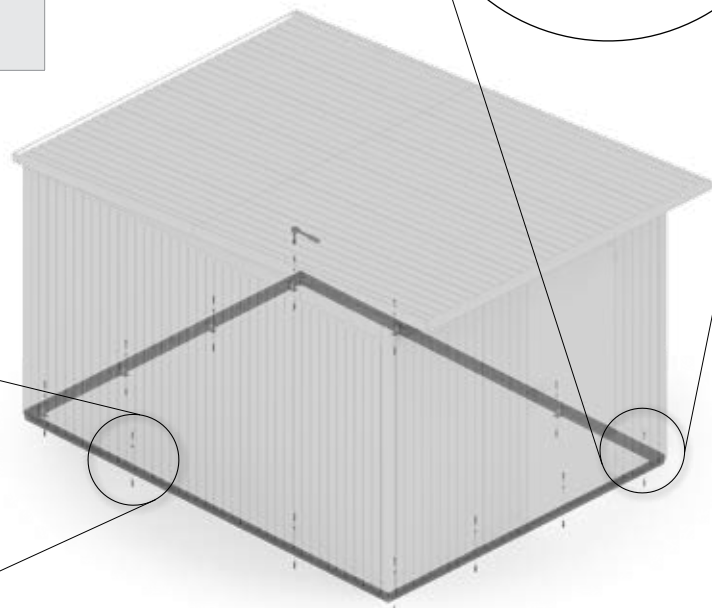
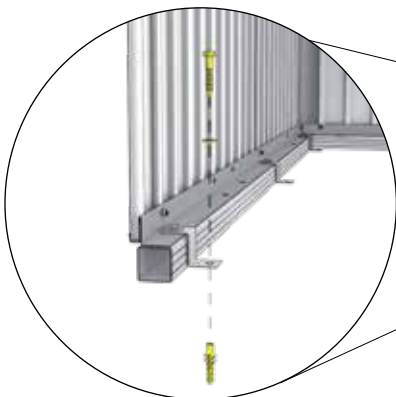
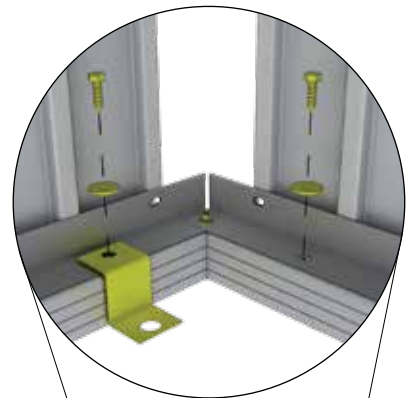

28.

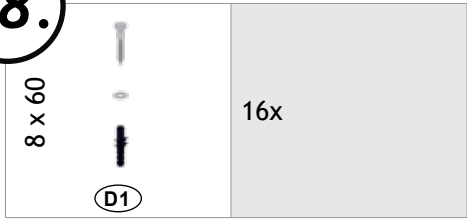

Variante 3, Proposal 3, Variant 3

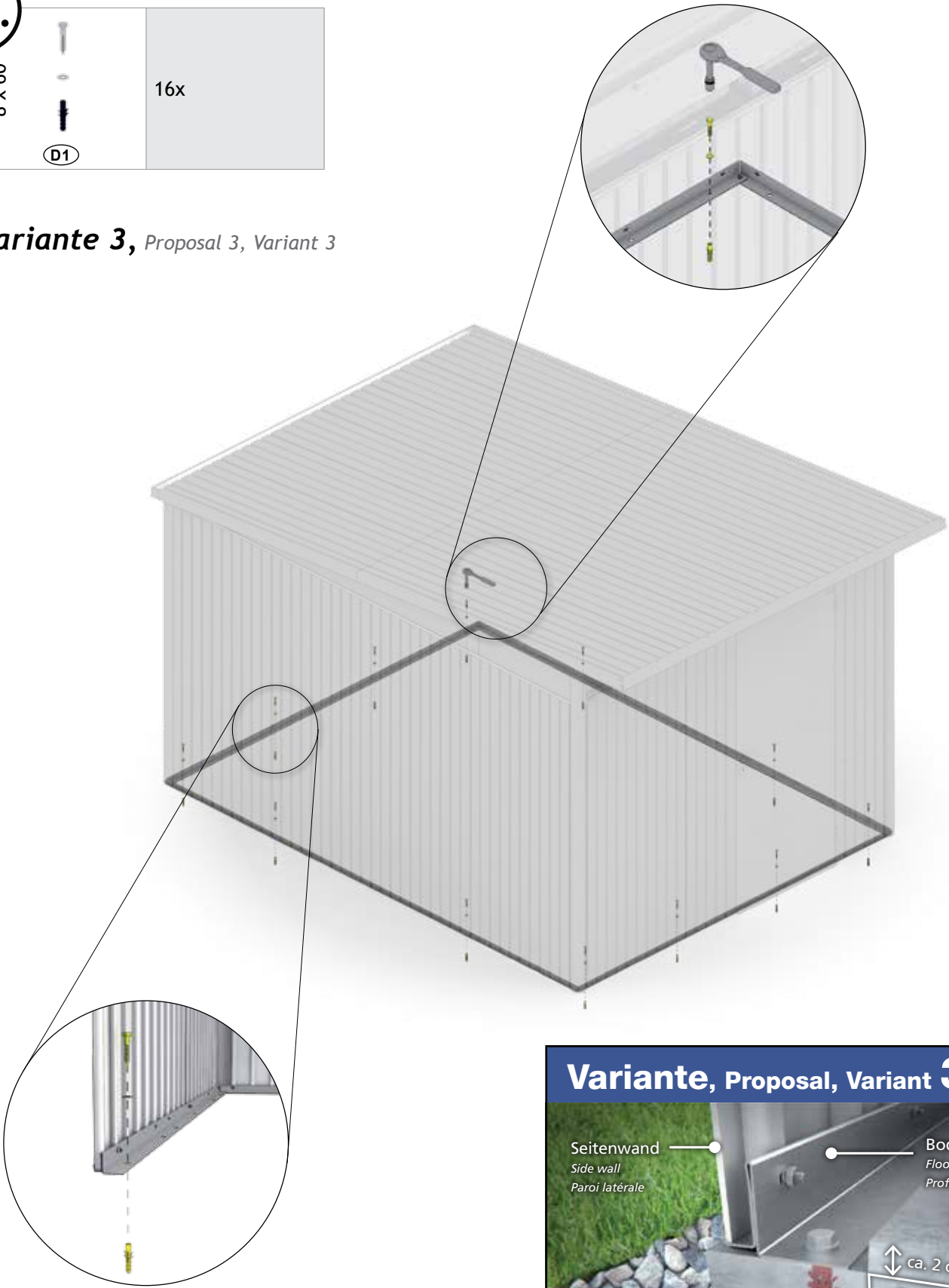

29.

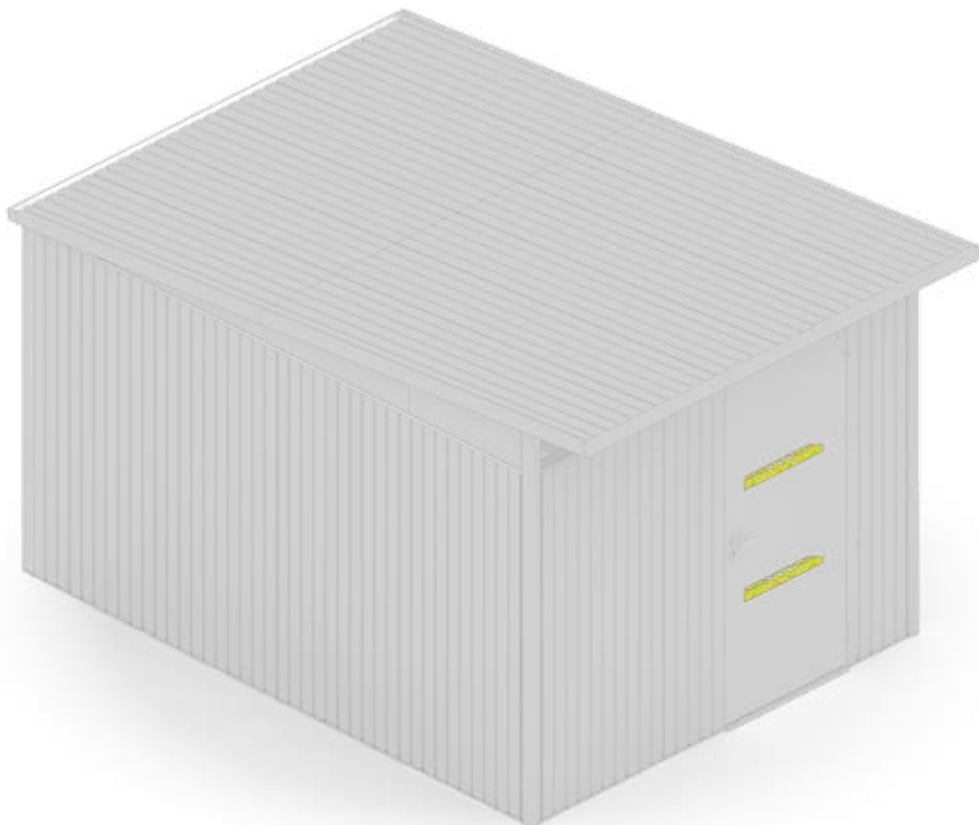
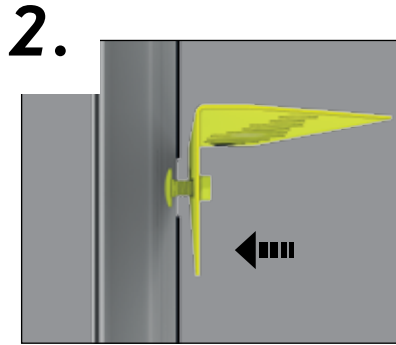
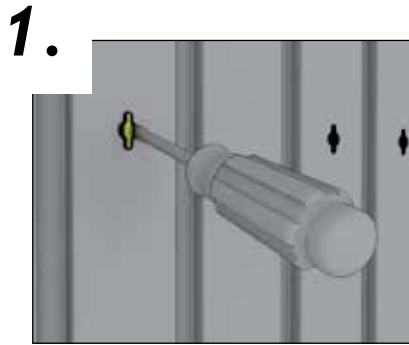
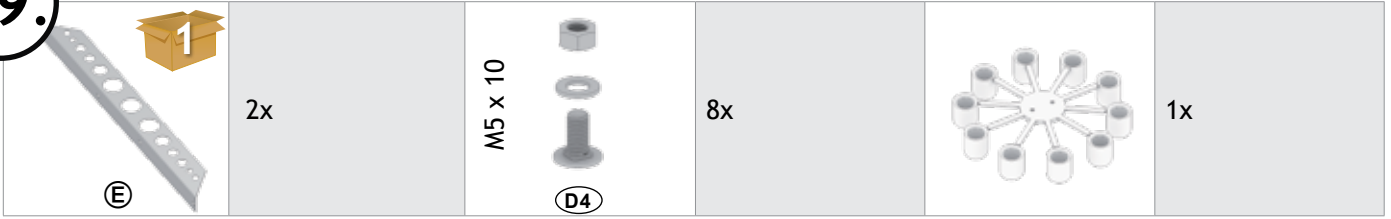

30.



**Option 1:**

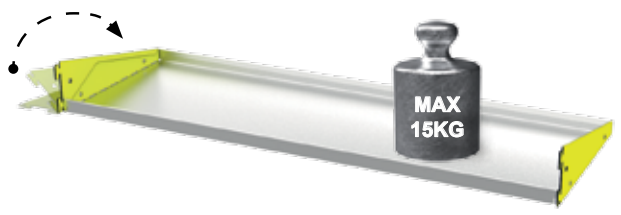

**Option 2:**

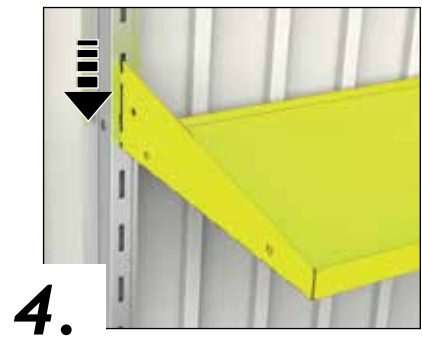
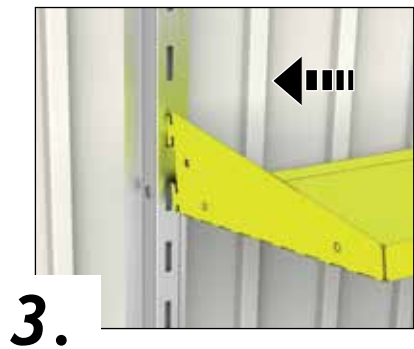
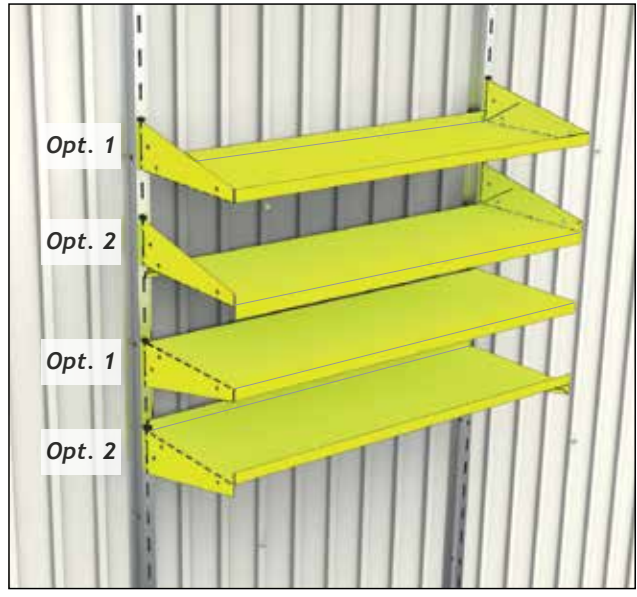





## Regenfallrohr

(Rain water downpipe - Descente d'eaux pluviales - Regenpijpset - Set di tubi pluviali - Set de bajante)

	2x	M4 x 10 	4x		2x
--	----	--	----	---	----

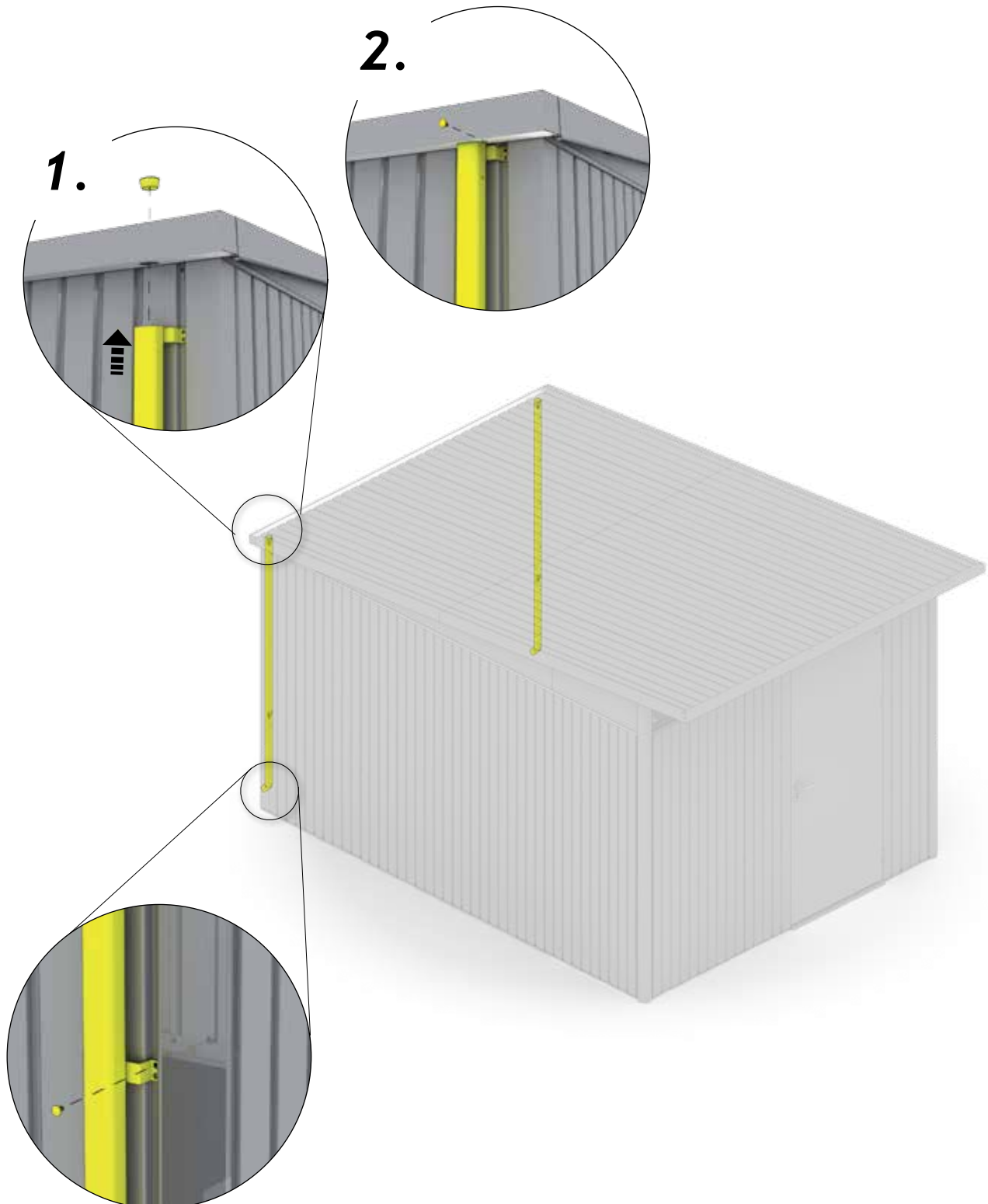

31.

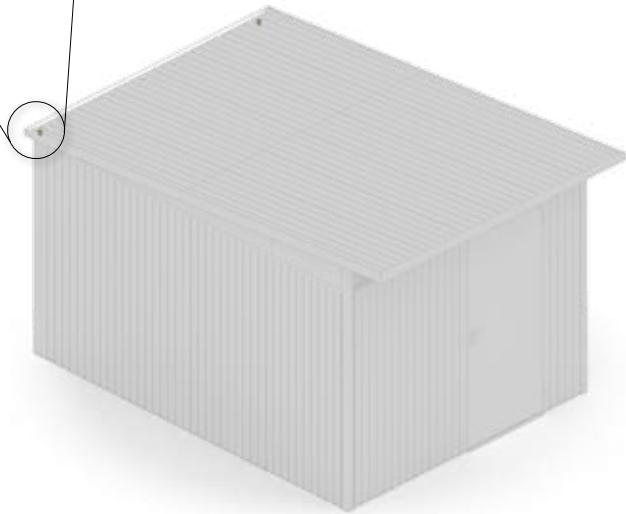
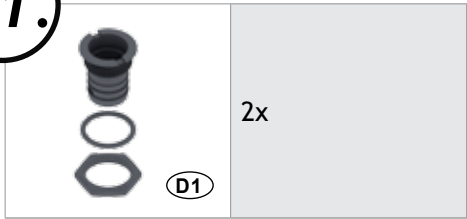

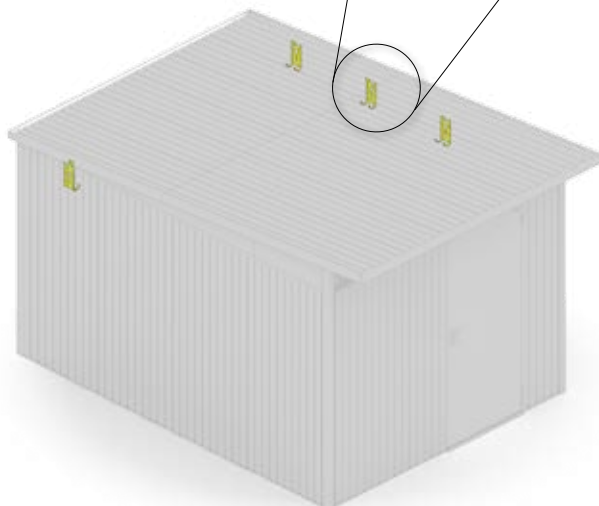
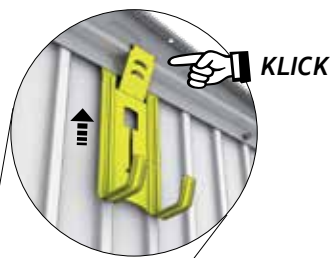
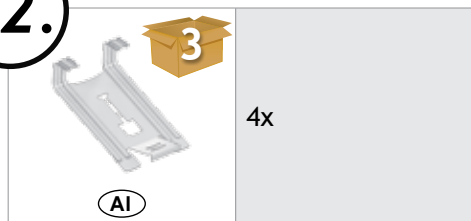

32.





## Bodenplatte

(Floor Panels - Cadre de sol - Plaque de fond - Bodemlaat - Placa de suelo - Pavimentazione)

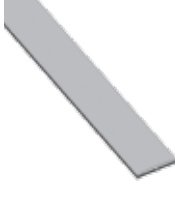
	11X (1250 x 600mm)		4X (2436 x 746mm) 1X (2436 x 235mm)		4X (2436mm)
--	--------------------	---	--	---	-------------

### Unterbau für Bodenplatten mit XPS-Platten (2cm od. 3cm) *(nicht im Lieferumfang)*

- Ⓒ GB Substructure of the floor panels with XPS-boards (2 cm | 3 cm) (not included in the scope of delivery)
- Ⓒ FR Les plaques XPS (2 cm | 3 cm)) pour les plaques de fond ne sont pas fournies.
- Ⓒ NL De XPS- platen die onder de bodemlaat komen, zijn bij de levering niet inbegrepen.
- Ⓒ ES Las placas XPS (2cm | 3 cm)) sobre las que se coloca la placa de suelo no forman parte del suministro.
- Ⓒ IT Placca XPS (2cm | 3 cm)) per basamento di una pavimentazione in alluminio non forniti in dotazione.

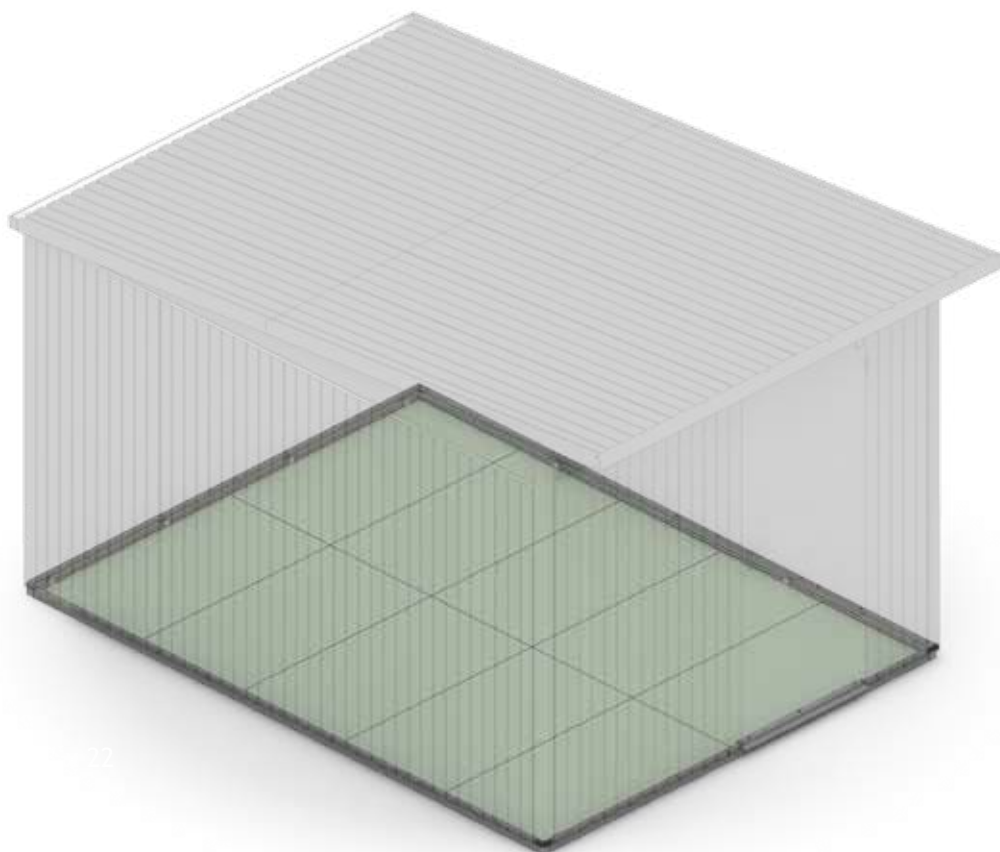

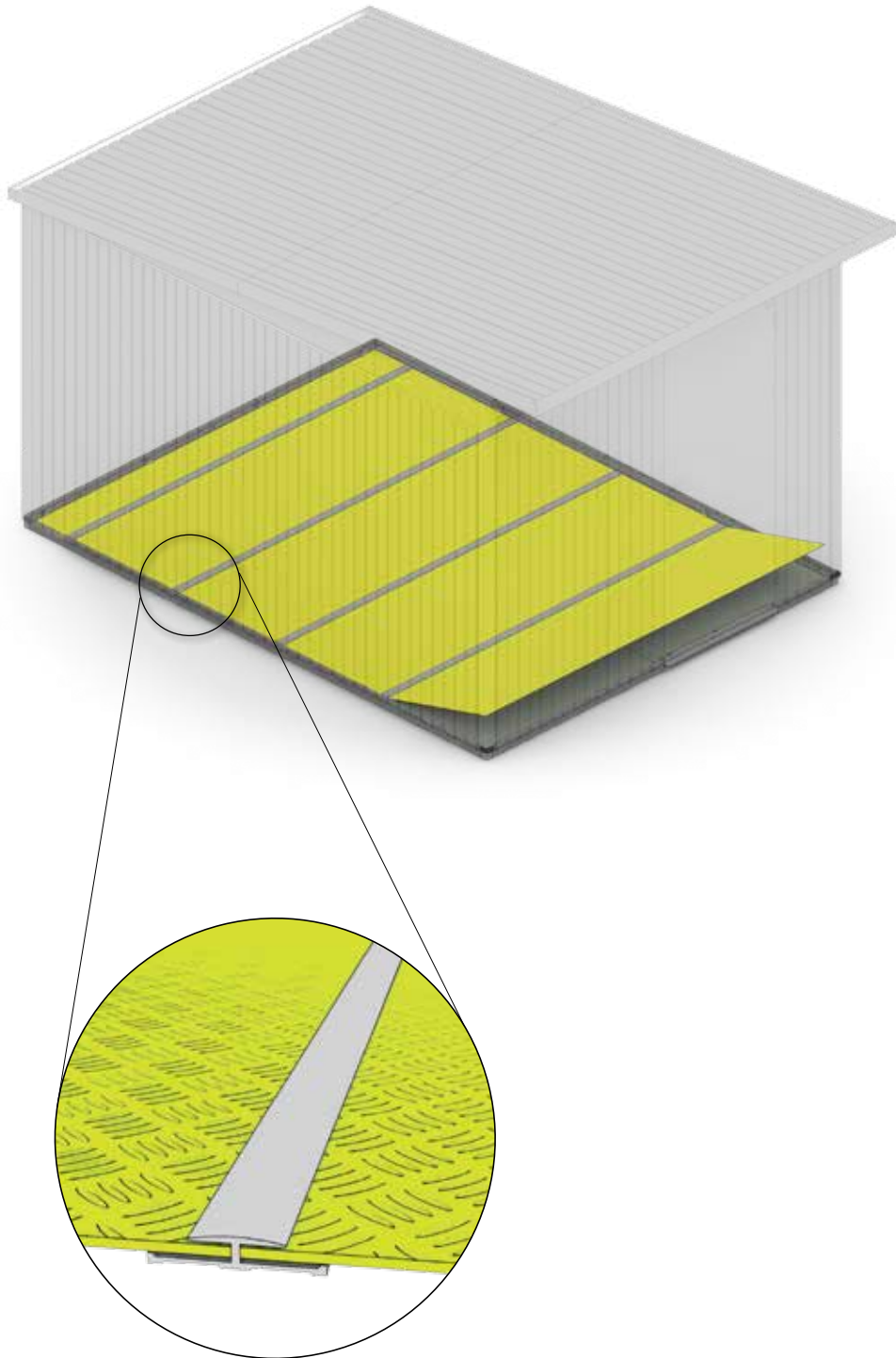



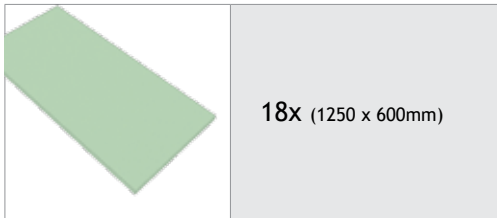

## optionale Dachisolierung mit Isolierplatten (2cm)

(nicht im Lieferumfang)

- Ⓒ GB ROOF INSULATION - polystyrene panels (2cm), (not in scope of supply)
- Ⓒ FR PRÉPARATION POUR L'ISOLATION DU TOIT - plaques de styrodur (2cm),  
(Pas inclus dans la livraison)
- Ⓒ NL VOORBEREID VOOR DAKISOLATIE - piepschuimplaten (2cm), (niet in leveringsomvang)
- Ⓒ ES PREPARACIÓN PARA EL AISLAMIENTO DE LA CUBIERTA - poliestireno (2cm),  
(No incluido en el volumen de entrega)
- Ⓒ IT PREDISPOSIZIONE PER LA COIBENTAZIONE DEL TETTO - di pannelli in polistirolo (2cm),  
(non forniti in dotazione)

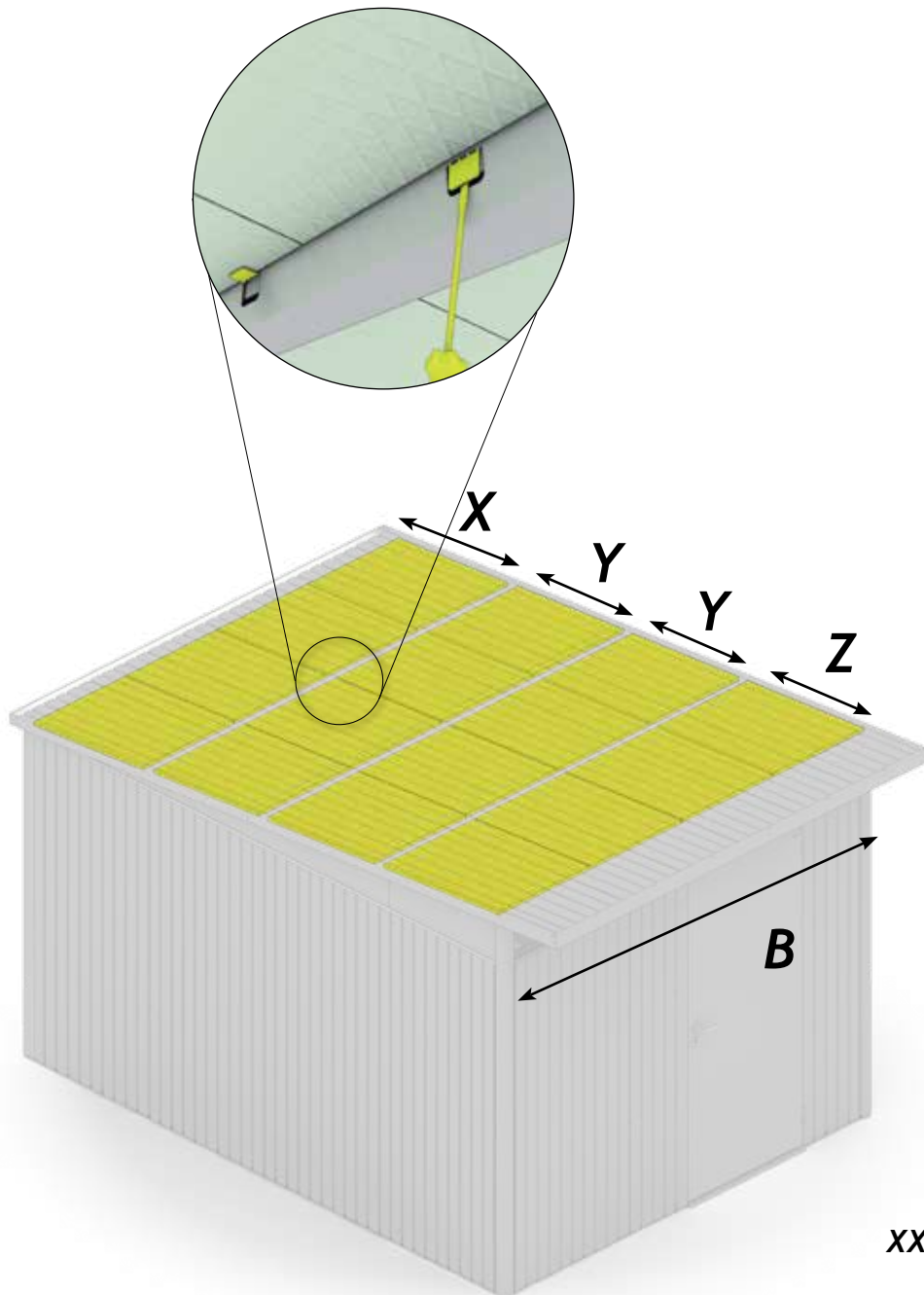

**XXL:** X = 760mm  
 Y = 740mm  
 Z = 805mm  
 B = 2530mm

# Einreichplan

für die Aufstellung eines  
Biohort-Gerätehauses  
Modell „AvantGarde“

Approval plan  
for the erection of  
Biohort garden shed  
model "AvantGarde"

Demande  
d'autorisation pour la  
mise en place d'un abri de  
jardin Biohort Modèle «  
AvantGarde »

Plan van  
goedkeuring  
voor het bouwen van het  
Biohort tuinhuis  
model "Avantgarde"

Adresse Aufstellort / Address at site of erection / Adresse du terrain / Platsingsadres

Grundbuch-Einlagezahl  
Land register-Site No. / Cadastre  
Katastralgemeinde

Grundstücks-Nr.  
Property No. / Parcelle n°  
Kadastraal nummer

Katastralgemeinde  
Council/Borough responsible  
Section/Commune / Eigendomsnummer

## Bauwerber

Building applicant

Demandeur / Opbouwer

Vorname / Christian name / Prénom / Voornaam Familienname / Surname / Nom / Achternaam

Anschrift / Address / Adresse / Adres

Unterschrift des Bauwerbers / Signature of applicant / Signature du demandeur / Handtekening eigenaar

## Grundstückseigentümer

Property owner

Propriétaire du terrain

Landeigenaar

Vorname / Christian name / Prénom / Voornaam Familienname / Surname / Nom / Achternaam

Anschrift / Address / Adresse / Adres

Unterschrift des Grundstückseigentümers / Signature of property owner  
Signature du propriétaire / Handtekening eigenaar

## Bodenfläche des Biohort-Gerätehauses:

Floorspace of biohort garden shed:

Surface au sol de l'abri de jardin Biohort :

Oppervlakte van het Biohort tuinhuis:

o Größe XXL / Size XL / Taille XL / Grootte XL = 8,5 m<sup>2</sup>

## Gesamte bebaute Fläche

Total built-up area / Surface totale bâtie / Totaal bebouwde oppervlakte

## Gartenfläche

Garden area / Surface du jardin / Tuin oppervlakte

## Altbau bewilligt

Erection authorised by

Permis de construire du bâtiment existant sur le terrain N°

Opdracht tot opbouw door

vom

Date / En date du / Datum

## Verein

Association / Société / Vereniging

## Lageplan 1 : 500

Siteplan 1 : 500

Plan de masse 1 : 500

Map 1 : 500

# Abmessungen Gerätehaus „AvantGarde“ XXL in cm

dimensions garden shed "AvantGarde" XXL in cm

dimensions des abri de jardin « AvantGarde » XXL en cm

afmetingen berging "AvantGarde" XXL in cm

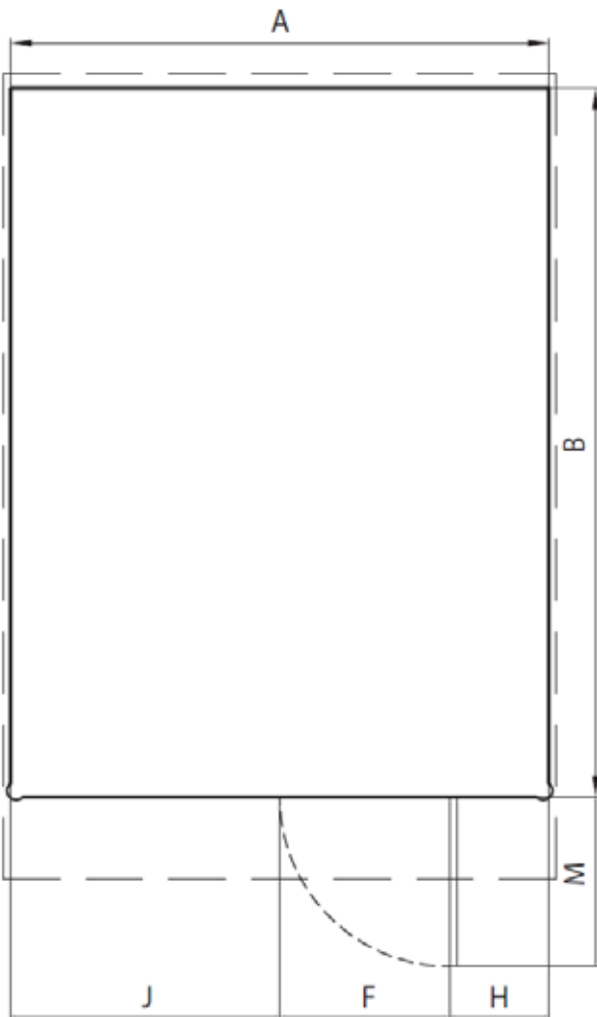
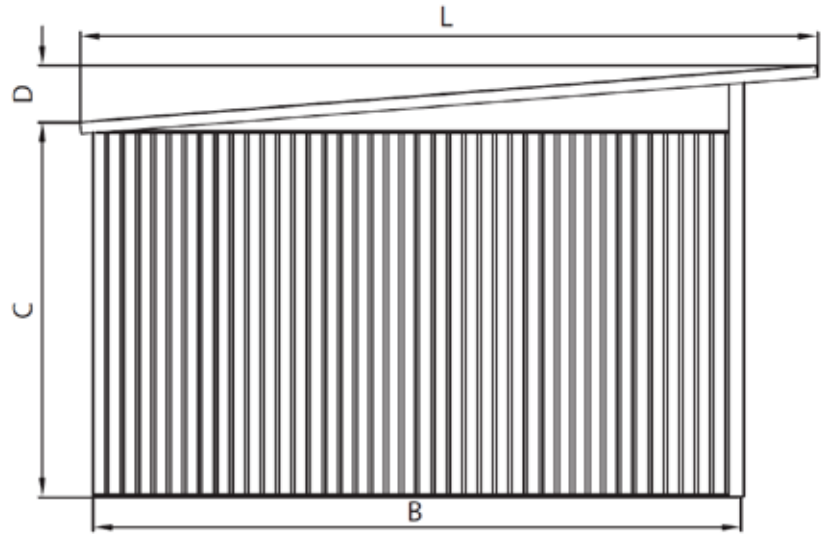
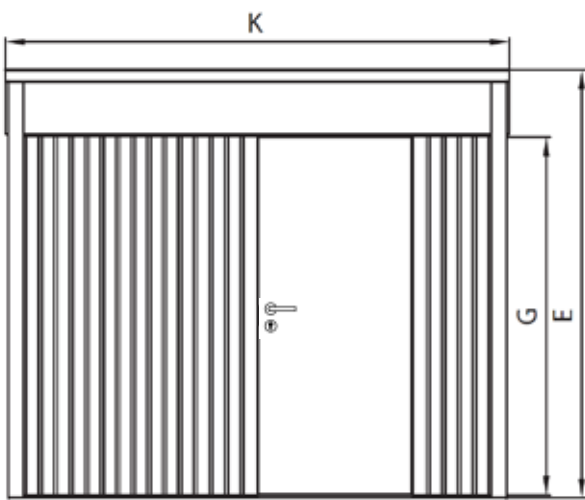

Maßbezeichnungen Description Dimensions référencées sur les dessins Benaming van de maten	Größe XXL size XXL taille XXL grootte XXL
<b>Gerätehausbreite (ohne Dachvorsprung)</b> Tool Shed width (excl. Roof overhang) Largeur de l'abri de jardin (sans débord de toit) Breedte berging (zonder luifel)	A 254
<b>Gerätehauslänge (ohne Dachvorsprung)</b> Tool Shed length (excl. Roof overhang) Longueur de l'abri de jardin (sans débord de toit) Lengte berging (zonder luifel) (zonder luifel)	B 334
<b>Gerätehaushöhe bis Regenrinne</b> Tool Shed height top edge of gutter Hauteur de l'abri de jardin jusqu'à la gouttière Hoogte berging tot de goot	C 193
<b>Höhe Regenrinne bis Dachoberkante</b> Height from top edge of gutter to roof ridge Hauteur de la gouttière jusqu'à la partie sup. du toit Hoogte dakgoot tot bovenkant van het dak	D 29
<b>Gerätehausgesamthöhe</b> • Tool Shed complete height Hauteur totale de l'abri de jardin • Totale tuinhuishoogte	E 222
<b>Durchgangslichte – Breite</b> Door opening – width Ouverture de passage de la porte - largeur Deuropening - breedte	F 76
<b>Durchgangslichte – Breite (optional 2.Türflügel)</b> Door opening – width (optional 2nd door wing) Ouverture de passage de la porte - largeur (option 2 battants) Deuropening - breedte (met optionele tweede deurvleugel)	(156)
<b>Durchgangslichte – Höhe</b> Door opening – height Ouverture de passage de la porte - hauteur Deuropening - hoogte	G 182
<b>Seitenbreite rechts</b> • Width of front facade - righthand side Largeur du côté droit • Zijbreedte rechts	H 49/129
<b>Seitenbreite links</b> • Width of front facade - lefthand side Largeur du côté gauche • Zijbreedte links	J 129/49
<b>Dachbreite</b> • Roof width • Largeur du toit • Dakbreedte	K 260
<b>Dachlänge</b> • Roof length • Longueur du toit • Daklengte	L 380
<b>Türplatzbedarf beim Öffnen</b> Clearance required for opening doors Encombrement d'ouverture de la porte Benodigde ruimte bij het openen van de deur	M 80



### HighLine®

Das ultimative Gerätehaus, das auch hinsichtlich Sicherheit und Funktionalität alle Anforderungen erfüllt: erhältlich in 5 Größen und in 3 Farben - weiß, silber-metallic, dunkelgrau-metallic



### AvantGarde

Passt bestens zu moderner Architektur und macht lebenslang Freude: erhältlich in 4 Größen und in 3 Farben - silber-metallic, quarzgrau-metallic, dunkelgrau-metallic



### Europa

Alles in bester Ordnung und lebenslange Wartungsfreiheit mit dem Biohort-Klassiker: erhältlich in 9 Größen und in 4 Farben - silber-metallic, quarzgrau-metallic, dunkelgrau-metallic, dunkelgrün



### Geräteschrank

Wo Raum knapp ist, zeigt er seine Klasse – im Garten, auf der Terrasse, in der Garage: erhältlich in 2 Größen und in 4 Farben - silber-metallic, quarzgrau-metallic, dunkelgrau-metallic, dunkelgrün



### WoodStock®

Kaminholzlager und Geräteschrank in einem, auch zum einfachen Wand-Anbau geeignet: erhältlich in 2 Größen und in 2 Farben - silber-metallic, dunkelgrau-metallic



### StoreMax®

Mit seinem funktionellen Design bietet der StoreMax® maximalen Stauraum auf wenig Platz: erhältlich in 3 Größen und in 3 Farben - silber-metallic, quarzgrau-metallic, dunkelgrau-metallic



### HighBoard

Das formvollendete Multitalent zum Aufbewahren: erhältlich in 2 Größen und in 3 Farben - weiß, silber-metallic, dunkelgrau-metallic



### LoungeBox®

Die Design-Box für gehobene Ansprüche - ein Schmuckstück für Terrasse und Garten: erhältlich in 3 Farben - weiß, silber-metallic, dunkelgrau-metallic



### FreizeitBox

Sie steckt locker all das weg, wofür Sie keinen geeigneten Aufbewahrungsort haben: erhältlich in 4 Größen und in 5 Farben - weiß, silber-metallic, quarzgrau-metallic, dunkelgrau-metallic, dunkelgrün



### Nebengebäude „CasaNova®“

Das erste isolierte Design-Nebengebäude: erhältlich in 9 Größen und in 2 Farben - silber-metallic, dunkelgrau-metallic



Kontrollnummer:  
Control-number / Contrôle-Qualité / Controlnummer:

Bei Reklamationen bitte anführen:  
Kontrollnummer und Artikelnummer des reklamierten Teils.

GB: In case of complaint please indicate the control-number and the number of the item, which is subject of complaint.

F: Pour toutes réclamations: prière de joindre le numéro de contrôle et le numéro d'article de la pièce litigieuse.

NL: Bij reclamaties svp doorgeven: controlnummer en artikelnummer van het desbetreffende onderdeel.



Biohort GmbH  
Pürnstein 43, 4120 Neufelden, Österreich  
Tel.: +43-7282-7788-0, Fax-DW: 190  
E-Mail: office@biohort.at, www.biohort.com

BH-1239-6B-1.1.15.Bt

